

GSFC ESDIS CMO
August 2020
Released

423-RQMT-003-D, Revision A
Earth Science Data and Information Systems (ESDIS) Project, Code 423

Appendix D. Metadata Requirements Base Reference for UNIFIED METADATA MODEL - SERVICE (UMM-S)



Goddard Space Flight Center
Greenbelt, Maryland

National Aeronautics and
Space Administration

Appendix D. Metadata Requirements Base Reference for Unified Metadata Model Services (UMM-S) Signature/Approval Page

Prepared by:

Name
Title/Role
Organization

Date

Reviewed by:

Name
Title/Role
Organization

Date

Approved by:

Name
Title/Role
Organization

Date

Concurred by:

Name
Title/Role
Organization

Date

**[Electronic] Signatures available in B32 Room E148
online at: / <https://ops1-cm.ems.eosdis.nasa.gov/cm2/>**

Preface

This document is under ESDIS Project configuration control. Once this document is approved, ESDIS approved changes are handled in accordance with Class I and Class II change control requirements described in the ESDIS Configuration Management Procedures, and changes to this document shall be made by change bars or by complete revision.

Any questions should be addressed to: esdis-esmo-cmo@lists.nasa.gov
ESDIS Configuration Management Office (CMO)
NASA/GSFC
Code 423
Greenbelt, Md. 20771

Abstract

This document describes the Unified Metadata Model (UMM) for Service (UMM-S) to be used by the National Aeronautics and Space Administration (NASA) Earth Science community and addresses the need for describing services available on data which is managed by repositories contributing their metadata to Common Metadata Repository (CMR). This community needs services that transform structured data into a form that is convenient to the end user. Developers, engineers and architects should reference this document and the UMM as a guide while implementing CMR components, CMR clients or services that make use of the CMR or CMR clients.

This version of the service model focuses on what service metadata is needed to support the User Interface/User Experience (UI/UX) leading to an improved user experience. The service model has been extended to include service metadata needed to support "machine-to-machine" operations. In general, the UMM covers both data and services. While the UMM-C (Collection), UMM-G (Granule) and UMM-Var (Variables) consider data, the UMM-S (Service) considers only services.

Keywords: UMM-S, UMM-C, UMM-G, UMM-Var, Services, NASA Earthdata Search, Tools, EOSDIS, ESDIS, CMR, GCMD, SERF

Change History Log

Revision	Effective Date	Description of Changes (Reference the CCR & CCB Approval Date)
Baseline, Original, Rev	10/31/2018	CCR 423-ESDIS-193; approved 10/10/2018 Baseline in COMET as stand-alone Appendix D to the Metadata Requirements Base Reference as Revision B. Pages: D-1 through D-71
Revision A	03/12/2020	CCR-423-ESDIS-277 ; CCB approved 01/24/2020 Annual UMM update. Pages D-1 through D-96

Table of Contents

D.1.INTRODUCTION	8
D.1.1 Purpose.....	8
D.1.2 Scope.....	9
D.1.3 Related Documentation.....	9
D.2.2.1 Applicable Documents.....	9
D.2.2.2 Reference Documents	9
D.1.4 Impact	10
D.1.5 Copyright Notice.....	10
D.1.6 Feedback	10
D.1.7 Document Conventions.....	10
D.2.SERVICES METADATA CONCEPTUAL MODEL.....	11
D.2.1 Use Cases	12
D.2.1.1 Collection Search	12
D.2.2.3 End-to-End Services request to an OPeNDAP service.....	15
D.2.2.4 Operation Request to a Web Service	18
D.2.2 UMM-S Metadata Model.....	20
D.2.2.1 Name [R].....	22
D.2.2.2 LongName [R]	22
D.2.2.3 Type [R].....	23
D.2.2.4 Version [R].....	23
D.2.2.5 VersionDescription	23
D.2.2.6 LastUpdatedDate.....	24
D.2.2.7 Description [R].....	24
D.2.2.8 URL [R]	24
D.2.2.9 ServiceKeywords [R].....	25
D.2.2.10 ServiceOptions.....	25
D.2.2.11 OperationMetadata.....	35
D.2.2.12 ServiceOrganizations [R].....	54
D.2.2.13 ContactPersons.....	54
D.2.2.14 ContactGroups	55
D.2.2.15 ServiceQuality.....	56
D.2.2.16 AccessConstraints	56
D.2.2.17 UseConstraints	57
D.2.2.18 AncillaryKeywords	57
APPENDIX A: DEPRECATED ELEMENTS	58
APPENDIX B: TAGS GLOSSARY	59
APPENDIX C: DEFINITIONS OF TERMS.....	60
APPENDIX D: EXAMPLES	63
APPENDIX E: ABBREVIATIONS AND ACRONYMS.....	69

List of Figures

Figure D-1. UMM Relationships showing key associations	12
--	----

Figure D-2. Collection Search Use Case	14
Figure D-3. Collection Search Activity Diagram	14
Figure D-4. Collection Search Sequence Diagram	15
Figure D-5. End-to-End Services request to an OPeNDAP service Use Case	16
Figure D-6. End-to-End Services request to an OPeNDAP service Activity Diagram	17
Figure D-7. End-to-End Services request to an OPeNDAP service Sequence Diagram.....	17
Figure D-8. Operation Request to a Web Service Use Case.....	18
Figure D-9. Operation Request to a Web Service Activity Diagram	19
Figure D-10. Operation Request to a Web Service Sequence Diagram	19
Figure D-11. Overall Service Model	21
Figure D-12. GeoTIFF file returned in the server response from a GetCoverage request for the AIRS3STD:SurfAirTemp_D_timeAveraged coverage	40
Figure D-13. GeoTIFF file returned in the server response from a GetCoverage request for the 980_14 coverage	41
Figure D-14. PNG file returned in the server response from GetMap request for the /sdat/config/mapfile//1286/1286_1_wms.map map.....	41

List of Tables

Table D-1. Cardinality	11
Table D-2. Tags Glossary	59

D.1. INTRODUCTION

Earth Observing System Data and Information System (EOSDIS) generates, archives, and distributes enormous amounts of Earth Science data via its Distributed Active Archive Centers (DAACs). These data are accessed and employed by a broad user community. It is therefore imperative that reliable, consistent, and high-quality metadata be maintained in order to enable accurate cataloging, discovery, accessibility, and interpretation. To increase the level of quality and consistency among its metadata holdings, EOSDIS has developed a model for various metadata concepts that it archives and maintains. This model aims to document vital elements that may be represented across various metadata formats and standards and unify them through core fields useful for data discovery and service invocations. This unified model, aptly named the Unified Metadata Model (UMM), has been developed as part of the EOSDIS Metadata Architecture Studies (MAS) I and II conducted between 2012 and 2013.

The UMM will be used by the CMR and will drive search and retrieval of metadata cataloged within that system.

This document describes a UMM reference model, referred to as the UMM-S, where 'S' stands for services. The updated UMM-S provides metadata to support the User Interface/User Experience (UI/UX)-driven approach to End-to-End Services. Specifically, when a user wants to know the service options for a specific service and makes selections via the UI, e.g., subsetting, data transformations, and the desired output file format. The UMM-S enables the population of the service options which are surfaced in the UI to support these selections. Each service record contains the identification of the service, i.e., name, type, version, description, service options for spatial, temporal, variable subsetting, other data transformations, and reformatting. An important consideration of how the capabilities of the service are captured in UMM-S is to ensure that it can be accessed by both humans, via the UI, and by machines, via the application programming interface (API).

D.1.1 Purpose

The purpose of UMM-S is to express a services model applicable to CMR that (1) stores service metadata, and (2) permits user selection of service options for data transformations which are provided by the service(s) for any given collection. In addition, the UMM-S model is related to the other CMR metadata models, e.g., UMM-Var, which supports the specification of variables which have associated services.

Note: the previous service design principally addressed the Service Entry Resource Format (SERF) standard. The SERF version of the service design included tools, software, and instances of services, including web services, US, and international web portals. NASA's EOSDIS is evolving to expose data and services using standards-based protocols in order to keep pace with evolving standards in web services, i.e., Open-source Project for a Network Data Access Protocol (OPeNDAP), Web Coverage Services (WCS), and Web Mapping Services (WMS). In recent work, the EED2 team sought to understand how data were being accessed, for what purpose, and how this could be more simply achieved via services. To develop this idea, the team has defined a User Interface/User Experience (UI/UX) driven approach to services. The user experience guides what selections and choices a user makes at the UI for typical data transformations, e.g., spatial subsetting, reprojection, reformatting, etc. The user is exclusively concerned about what choices are available for a specific data set and the back-end services take care of any needed processing.

This document provides information to the NASA Earth Science community. Distribution is unlimited.

D.1.2 Scope

This document describes the UMM Service (UMM-S) model version 1.3.4.

D.1.3 Related Documentation

The latest versions of all documents below should be used. The latest ESDIS Project documents can be obtained from Uniform Resource Locator (URL): <https://ops1-cm.ems.eosdis.nasa.gov>. ESDIS documents have a document number starting with either 423 or 505. Other documents are available for reference in the ESDIS project library website at: http://esdisfmp01.gsfc.nasa.gov/esdis_lib/default.php unless indicated otherwise.

D.2.2.1 Applicable Documents

The following documents are referenced within, are directly applicable, or contain policies or other directive matters that are binding upon the content of this document.

Document Number	Document Title
N/A	CMR Life Cycle https://wiki.earthdata.nasa.gov/display/CMR/CMR+Documents
N/A	CMR End-To-End Services Study (Task 25) EED2-TP-025 https://wiki.earthdata.nasa.gov/download/attachments/83624411/EED2-TP-025_CMR%20End-To-End%20Services%20Study.pdf?api=v2

D.2.2.2 Reference Documents

The following documents are not binding on the content but referenced herein and, amplify or clarify the information presented in this document.

Document Number	Document Title
N/A	Tags http://en.wikipedia.org/wiki/Tag_%28metadata%29
N/A	XPath XPath is a language for addressing parts of an XML document, designed for use with XSLT.

D.1.4 Impact

This document outlines a profile intended to be backward compatible with existing NASA Earth Science metadata implementations. It will impact providers from NASA DAAC[s], CMR client developers, metadata catalog developers, and users.

D.1.5 Copyright Notice

The contents of this document are not protected by copyright in the United States and may be used without obtaining permission from NASA.

D.1.6 Feedback

Questions, comments and recommendations on the contents of this document should be directed to support@earthdata.nasa.gov.

D.1.7 Document Conventions

There are two main sections to the rest of this document: the use cases and the detailed description of the metadata model. The use case section describes the use cases used to create the metadata model. Each use case section contains the following information:

- Scenarios: One or more related scenarios are described in this section.
- Outcomes: A description of what the system provides the user as a result of the scenarios.
- Use Case Diagram: A diagram that highlights the actor's interaction with the system.
- Activity Diagram: A diagram that shows the flow of data in terms of the user experience.
- Sequence Diagram: A diagram which shows the key components of the system and the sequences of actions within the system.

The detailed description of the metadata model section of this document describes each element within the model. Elements of the Service model are documented in the following way:

- Element Name: Specifies the element name.
- Element Specification: Provides the sub-elements, cardinality of the sub-elements within (), any valid values within <>, applicable comments and notes within {}, and any other major factors that make up the element.
- Description: Provides background information on the purpose of the element and how it should be used. Any notes about the current usage of this element are documented here as well as any recommendations for usage or unresolved issues.

- **Tags:** Provides specific, related categorical values associated with this element, which are defined in Appendix B Tags Glossary.

With the exception of Element Name each of the element's sections are that are included are listed in bold to make it easier for the reader to distinguish between the element's section headings and the descriptions.

Table D-1. Cardinality

Value	Description
1	Exactly one of this element is required
0..N	This element is optional; up to and including N number of this element may be present
0..*	Optionally, many of this element may be present
1..*	At least one of this element is required, many may be present

The [R] after an element name indicates that the element is required.

D.2. SERVICES METADATA CONCEPTUAL MODEL

Any service metadata described by the UMM-S may be associated with other metadata in the UMM, such as collection (UMM-C) metadata, granule (UMM-G) metadata, and variables (UMM-Var). In addition, as shown in Figure 1, the associations in the UMM support the discovery of services from a given collection or variable. This model will support the concept of data (represented by metadata contained within the UMM-C, UMM-G, UMM-Var) being discovered, requested, and subsequently transformed via the corresponding service. The other UMM models reside in Jama in separate projects. The CMR Lifecycle represents how metadata is managed over time and will govern this model, all related documentation, and facilitate change. The CMR Lifecycle is documented in a Wiki page located at: <https://wiki.earthdata.nasa.gov/display/CMR/CMR+Documents>.

Figure 1 shows the UMM-S metadata model at a high-level and specifically depicts the relationship of UMM-S to the other models in the context of the UMM by mapping its relationships with the other key entities: Collection, Granule, and Variable. These entities are represented in abbreviated forms with only a few key identifiers listed in each class.

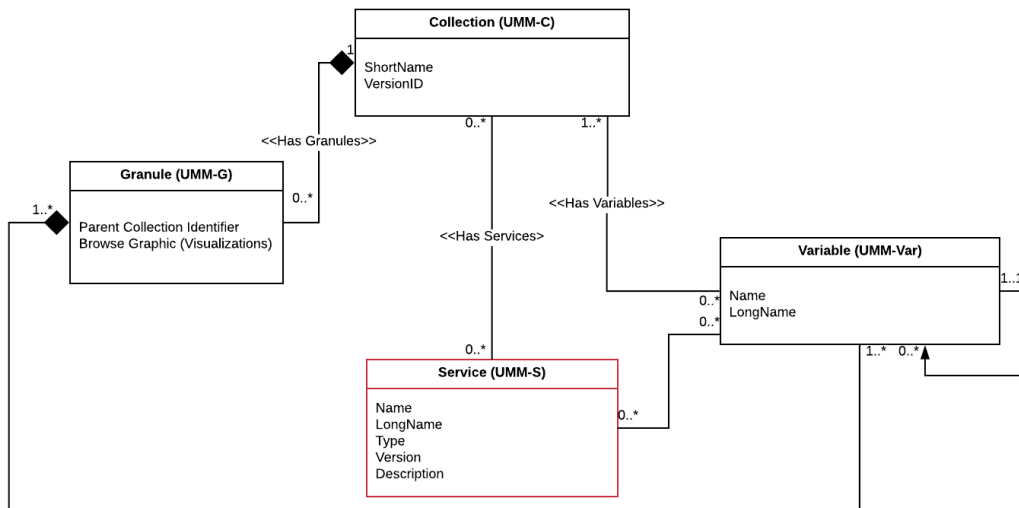

Figure D-1. UMM Relationships showing key associations

D.2.1 Use Cases

This section provides information about use cases identified for the UMM-S. In keeping with the UML methodology, we provide several diagrams that describe different information. A use case diagram shows the actor's interaction with the system. An activity diagram shows the flow of data in terms of the user experience. A sequence diagram shows the sequences of actions within the system and the key components of the system.

D.2.1.1 Collection Search

As a user of the Earthdata Search (EDSC), I can perform a Collection Search and discover the associated variables and service options listing the data transformations from the CMR.

Scenario [a]: As a user of the EDSC, I can get a list of collections from the CMR. For each collection, I can determine whether the following logical operators are "true" or "false": "has_variables", "has_transforms" or "has_formats".

Scenario [b]: As a user of the EDSC, I have a collection from the CMR, and I can subsequently make a request to return all the variables and the associated service options. The service options include information about the data transformations, including subset options, re-projections and format conversions.

Scenario [c]: As a user of the EDSC, I can select collection(s) and I can make a request to the CMR which returns all the variables and service options for those collection(s).

Outcomes: As an EDSC user, with no knowledge of the service capabilities listed in the CMR, I can perform a collection search and subsequently discover the variables, the service(s) and service options. These will enable the EDSC user to determine whether the collections have variables, transforms, and formats; as well as to gather the details of these and make selections in the UI modals - which are captured in the user's project. These selections can be subsequently used to make a data transformation request from the service, to enable spatial, temporal or variable subsetting, reprojection, or reformatting.

Definitions:

Variable: A named set of data that contains the values of a measurement. In this context, the variable is described by its name and characteristics. The description includes what was intended to be measured (i.e., the observable property, and how the variable was measured (e.g., measurement technique and the instrument used). Variables may be classified as science variables, quality variables and ancillary variables (or other, when one of these classifications cannot be used). A variable can also be the output of a model.

Service: A service has various abilities to transform variables. The service can be remotely accessed via a Representational State Transfer (REST) end point, e.g., a web service.

Data Transformation (or transform): A data transformation is a specific capability available from a service, e.g., spatial subsetting or reprojection. It is an umbrella term that represents a method for transforming data from one form to another. For example: spatial subsetting might be used on data that exists with a global extent, to subset it to a regional extent. The list of data transformations available is service provider dependent, e.g., at Goddard Earth Sciences Data and Information Services Center (GES DISC), a typical OPeNDAP service provides: spatial subsetting, variable subsetting, and data format conversion. This list of data transformations available is dependent on the service provider.

Format: The file format used to store the data on the file system. The data can be transformed to a different format through the use of a service, e.g., HDF4 -> GeoTIFF. The native file format and the list of available output file formats will be available from the UMM-S.

Note: Within the EDSC UI, there are three modal windows when we arrive to the point of selections of service options in the workflow: the first to list the Variables (which have services), a second for Data Transformations, and a third for formats. In the model, we don't need to separate the formats out into its own class, provided the model can support the UI, in terms of what metadata it needs to "surface".

Use Case: See the use case diagram below.

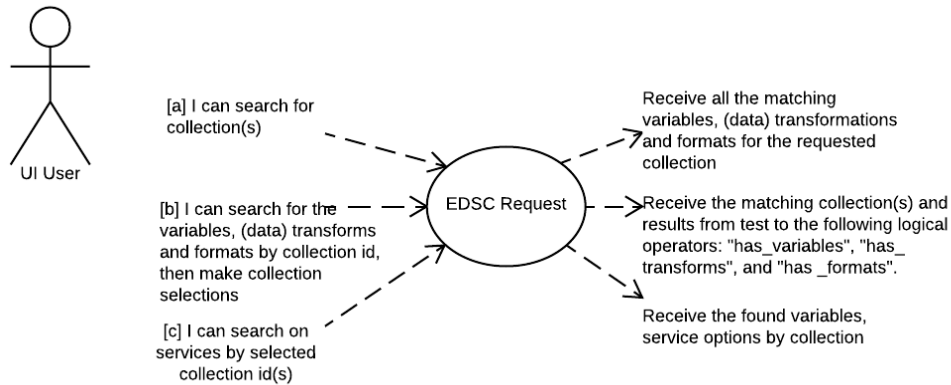

Figure D-2. Collection Search Use Case

User Experience: See the activity diagram below.

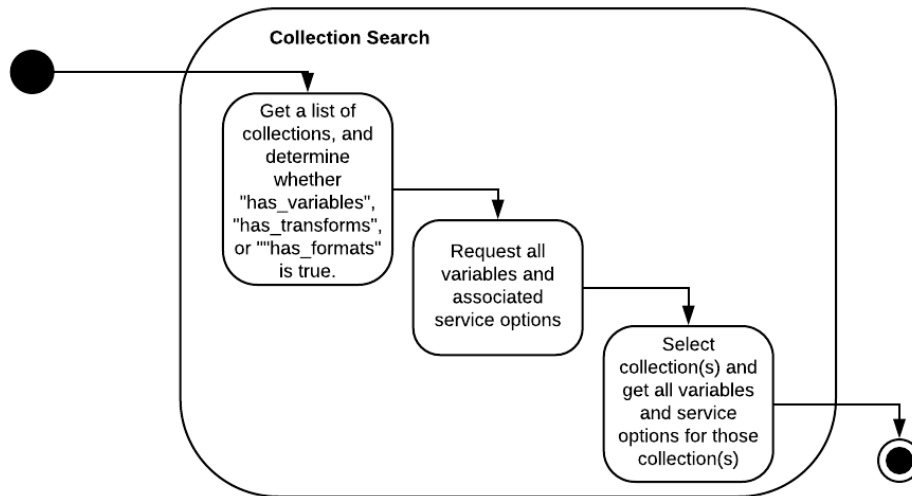

Figure D-3. Collection Search Activity Diagram

Workflow: See the sequence diagram below.

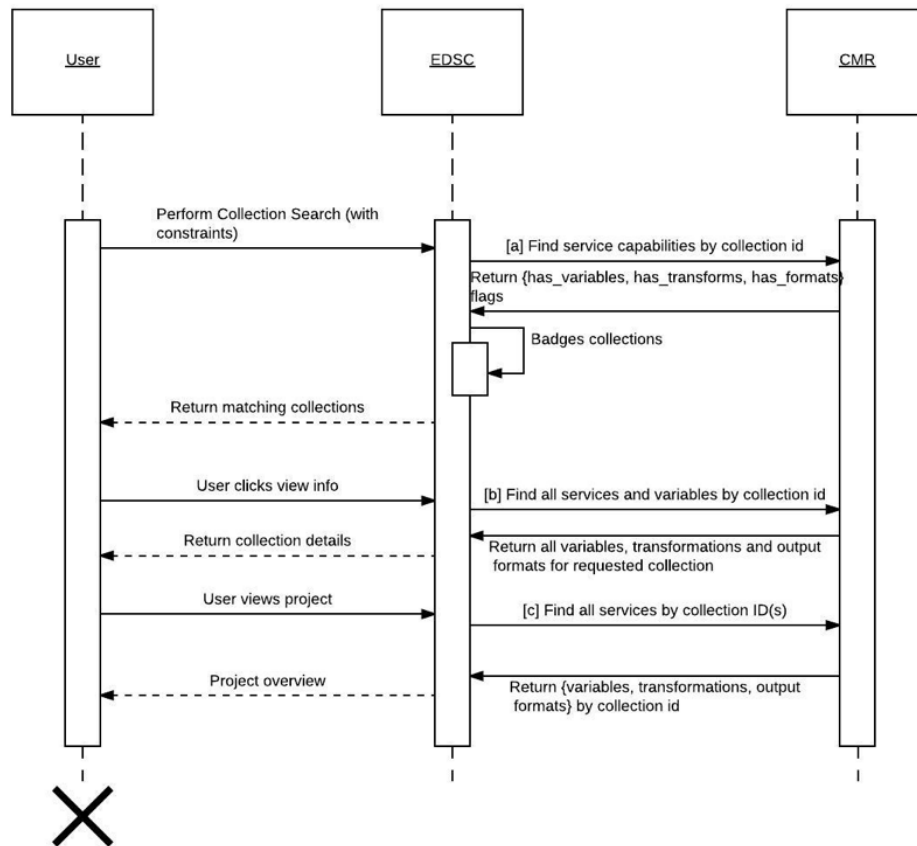

Figure D-4. Collection Search Sequence Diagram

D.2.2.3 End-to-End Services request to an OPeNDAP service

As a user of the EDSC, I can select the variables associated with a collection and choose service options for the data transformations I want to invoke.

Scenario [a]: As a user of the EDSC, I have made a collection selection, following a collection search. For that collection, I can select the variable, or variables of interest. I can select the service options, in terms of whether I need spatial, temporal, or variable subsetting. I can select the Supported Projections for both input and output projections from a list. I can select the Supported Formats for both input and output formats from a list.

Scenario [b]: As a user of the EDSC, I can invoke a subsetting request which is governed by the service options chosen, and can receive the subsetted data via a link, or links listed in the response.

Outcomes: As an EDSC user, after having selected a collection and variable, or variables of interest, I can invoke a subsetting request and subsequently receive the links to the variable, or variables I selected. The service options specific to that variable, or variables are offered as selections in the UI modals - which are presented prior to invoking the subsetting request. The EDSC enables an intuitive method of making a data transformation request to the OPeNDAP service, to enable spatial, temporal or variable subsetting, reprojection, or reformatting.

Note: the current implementation of End-to-End Services is limited to OPeNDAP services, and hence the capabilities of the various service options are limited to the capabilities which can be invoked by an OPeNDAP service.

Use Case: See the use case diagram below.

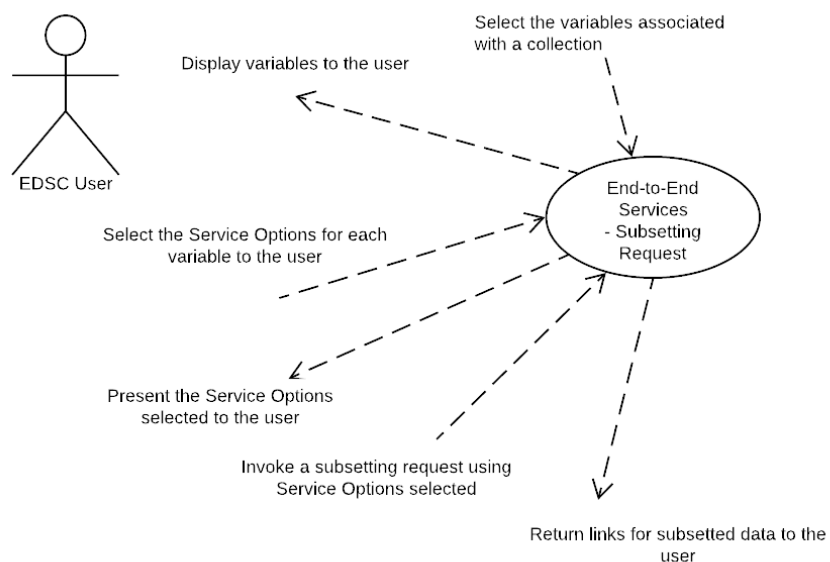

Figure D-5. End-to-End Services request to an OPeNDAP service Use Case

User Experience: See the activity diagram below.

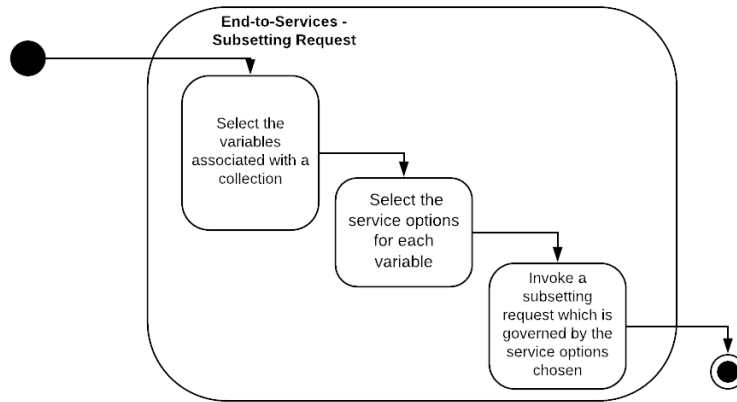

Figure D-6. End-to-End Services request to an OPeNDAP service Activity Diagram

Workflow: See the sequence diagram below.

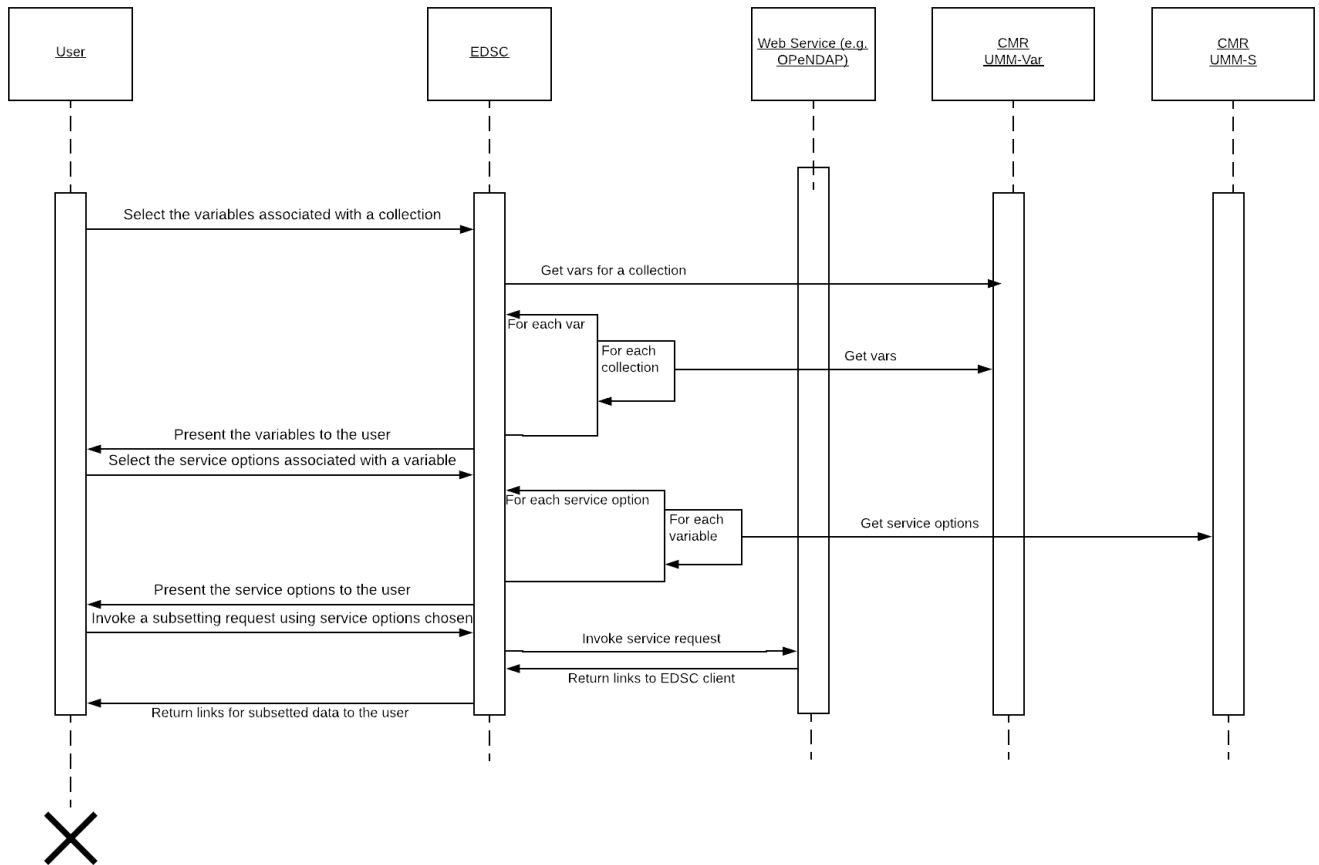

Figure D-7. End-to-End Services request to an OPeNDAP service Sequence Diagram

D.2.2.4 Operation Request to a Web Service

Send an Operation Request to a web service. The User receives the Coverage within the multipart XML response from the web service.

Scenario [a]: As a user of the EDSC or other CMR client, I can make a request for a GetCapabilities operation by discovering the operations supported by a hosted web service.

Scenario [b]: As a user of the EDSC or other CMR client, I can constrain the request to a desired coverage, spatial extent, temporal extent, projection and format.

Scenario [c]: As a user of the EDSC or other CMR client, I can receive the XML response, containing the coverage in a multipart from the web service.

Outcomes: User obtains Coverage from a multipart XML response for subsequent display, or data usage.

Use Case: See the use case diagram below.

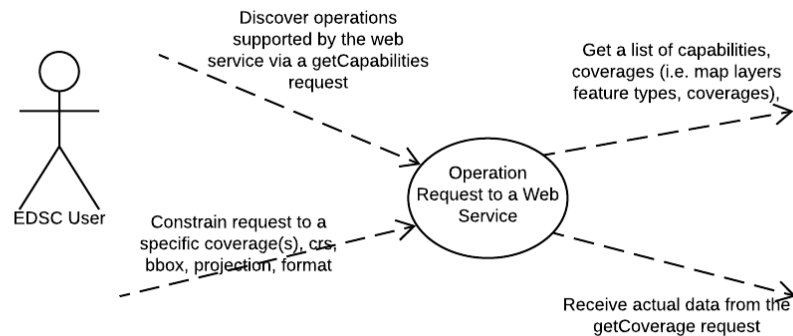

Figure D-8. Operation Request to a Web Service Use Case

User Experience: See the activity diagram below.

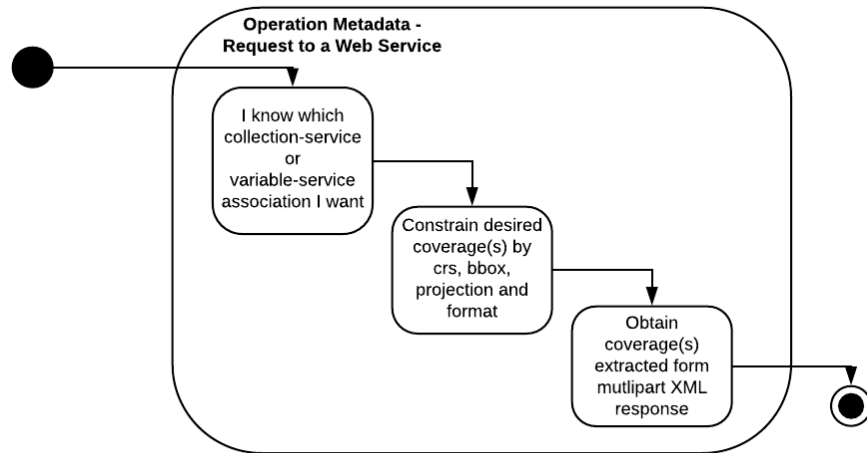

Figure D-9. Operation Request to a Web Service Activity Diagram

Workflow: See the sequence diagram below.

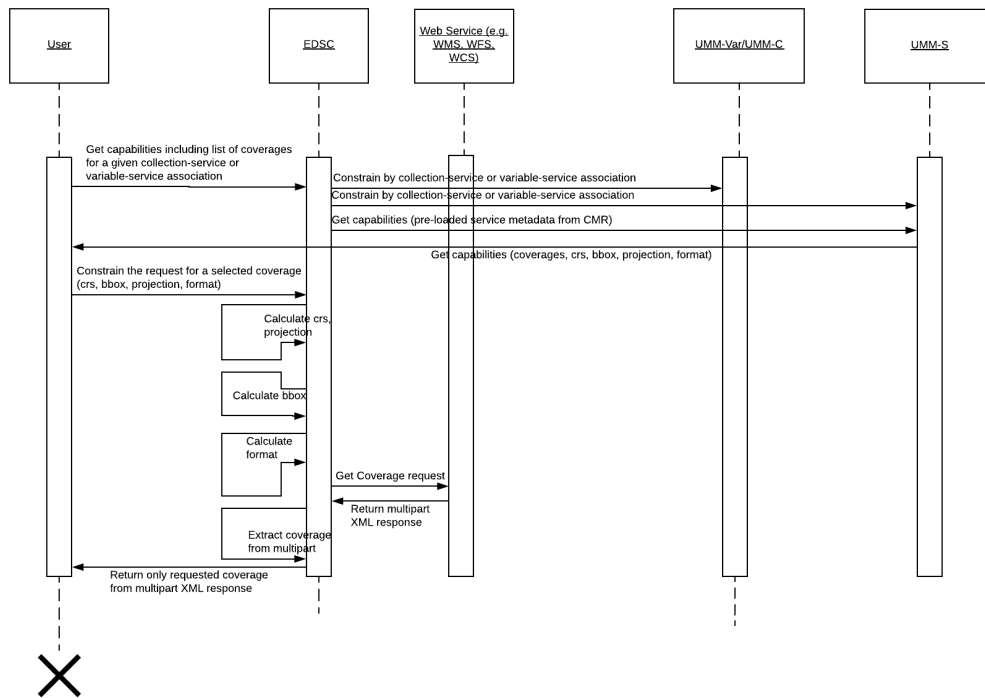

Figure D-10. Operation Request to a Web Service Sequence Diagram

D.2.2 UMM-S Metadata Model

The service metadata conceptual model shown in Figure 11 shows the model broken down into three major classes for Services: Service, ServiceOptions, and OperationMetadata with each class describing a different aspect of the service. There are also some minor classes: URL, RelatedURLs, ServiceKeywords, ServiceOrganizations, ContactPersons, ContactGroups and ServiceQuality, which capture other important information about the service. The Collection (UMM-C) and Variable (UMM-Var) models are represented here to highlight these important relationships with the Service class. Each aspect is described in more detail in the subsequent sections of this document.

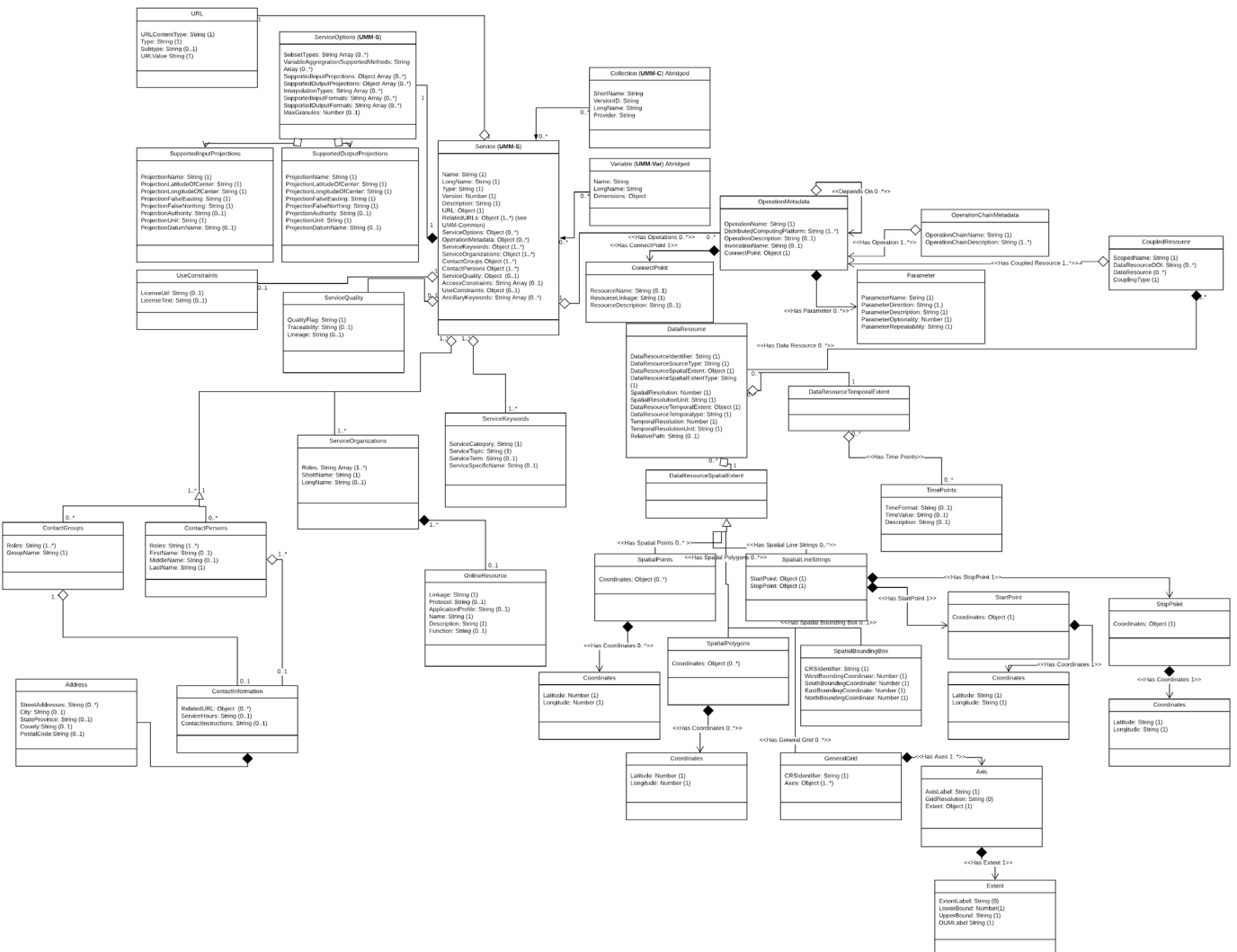

Figure D-11. Overall Service Model

The function of the Service class is to enable the service to be specified by its unique service metadata. Each service will be identified in terms of its name, long name, type, version, and description. The URL class is used to capture the important URL which represents the linkage to the service. The URL class has attributes which are used to describe the URL, and it is strongly typed. The RelatedURLs class is used to capture important URL(s) related to the service, i.e. a web page of service provider home page describing the service. The RelatedURLs class has attributes which are used to describe these URLs, and it is strongly typed.

The function of the Options class is to capture the various data transformations supported by the service.

The function of the OperationMetadata class is to capture RESTful service endpoint(s) for the service, the nature of the coupled resource, and specific information about the WMS layer, Web Feature Service (WFS) feature type, or WCS coverage. If the service has layers, feature types or coverages, then the identifier, relative path, and any spatial and temporal information may be specified, for each layer, feature type or coverage.

Note: Typical WMS layers can be mapped 1:1 with the variables represented in UMM-Var, but the name of the layers sometimes differs from the variable names. This is dependent on choices in naming layers made by the service provider. This is also true of WFS feature types, or WCS coverages. The DataResource class is a generic class which enables the layer, feature or coverage names used as the identifiers to be captured, along with other information about their spatial and temporal extents.

All of the service elements will be described next. The order in which they appear is the same order in which they are listed in Figure 11 in the Service class.

D.2.2.1Name [R]

Element Specification

Name (1)

Description

The name of the service.

Sample Values:

- service example: "SERVIR"
- OPeNDAP example: "AIRS_L3_OPENDAP"
- Mirador example: "GES_DISC_via_OpenSearch_(Mirador)"

Tags

Required

D.2.2.2LongName [R]

Element Specification

LongName (1)

Description

The long name of the service. It provides a human readable name for the service.

Sample Values:

- service example: "Mesoamerican Visualization and Monitoring System (SERVIR)"
- OPeNDAP service example: "OPENDAP (Hyrax) framework for AIRS Level 3 data products"
- Mirador service example: "Access the GES DISC data via OpenSearch (Mirador)"

Tags*Required*

D.2.2.3Type [R]

Element Specification

Type (1) <OPeNDAP, THREDDS, WEB SERVICES, ESI, ECHO ORDERS, WCS, WFS, WPS, CSW, WMTS, WMS, Harmony, NOT PROVIDED>

Description

The type of the service. The valid values will come from the Keyword Management System (KMS), which is a controlled list.

Sample Value: WCS

Rationale for Change

UMM-S will only support back-end service types.

Tags*Required, Controlled Vocabulary*

D.2.2.4Version [R]

Element Specification

Version (1)

Description

The edition or version of the service. The version should be defined in the form x, y, and z, where 'x.y.z' means 'major.minor.incremental' version numbers. Typically, 'x' and 'y' are numbers (0 through 9) and 'z' is a number (0 through 99).

Sample Value: 1.1.1

Tags*Required*

D.2.2.5VersionDescription

Element Specification

VersionDescription (0..1)

Description

This field provides users with information on what changes were included in the most recent version.

Tags*Recommended*

D.2.2.6LastUpdatedDate

Element Specification

LastUpdatedDate (0..1)

Description

This element describes the latest date when the service was most recently pushed to production for support and maintenance.

Tags*Recommended*

D.2.2.7Description [R]

Element Specification

Description (1)

Description

A brief description of the service. For example, a description might contain information about what is the service, the purpose of the service, and the parameters (or variables) being invoked, and what are the sources of these data.

Sample Values:

- service example: "The SEDAC Hazards Mapper enables users to visualize data and map layers related to Socioeconomic, Infrastructure, Natural Disasters, and Environment and analyze potential impacts and exposure. The web app mashups layers from various sources including SEDAC, NASA LANCE, NASA GIBS, USGS, NOAA, ESRI, and others.
- OPeNDAP service example: "OPeNDAP (Hyrax) Framework for AIRS L3 data products. This framework facilitates such services as format conversion and selected subsetting (e.g., spatial constraints, parameter/variable)."

Tags*Required*

D.2.2.8URL [R]

Element Specification

URL(1)

URL/Description (0..1)

URL/URLValue (1)

Description

This element describes the Specific URL to the back-end service.

The following examples show how the above fields should be completed for service examples.

Sample Values:

Description: "SERVIR-Mesoamerica is regional service that provides a suite of analysis and visualization tools that integrate satellite and other geospatial data"

URL Value: "https://www.servirglobal.net/default.aspx"

D.2.2.9 ServiceKeywords [R]

Element Specification

ServiceKeywords (1..*)

ServiceKeywords/ServiceCategory (1)

ServiceKeywords/ServiceTopic (1)

ServiceKeywords/ServiceTerm (0..1)

ServiceKeywords/ServiceSpecificTerm (0..1)

Description

Allows for the specification of Earth Science Service keywords that are representative of the service being described. The controlled vocabulary for Service Keywords is maintained in the KMS.

Sample Value: "ServiceCategory: Earth Science Services, ServiceTopic: Data Management/Data Handling, ServiceTerm: Data Search and Retrieval".

Tags

Required, Controlled Vocabulary

D.2.2.10 ServiceOptions

Element Specification

ServiceOptions (0..*)

ServiceOptions/Subset (0..1)

ServiceOptions/VariableAggregation (0..*)

ServiceOptions/SupportedInputProjections (0..*)

ServiceOptions/SupportedOutputProjections (0..*)

ServiceOptions/InterpolationTypes (0..*)

ServiceOptions/SupportedReformattings (0..*)

ServiceOptions/SupportedReformattings/SupportedInputFormats (1)

ServiceOptions/SupportedReformattingsSupportedOutputFormats (1..*)

ServiceOptions/MaxGranules (0..1)

Description

The ServiceOptions element is used to identify the list of supported data transformations. The term "data transformations" is a general term to describe a variety of ways data can be transformed by the service. The list of valid data transformations has been sourced from the Data Transformations Working Group and include the following:

- Subsetting by geographic region
- Subsetting by time
- Subsetting by variable

- Reprojection
- Reformatting
- Regridding
- Variable Aggregation

Each of the ServiceOptions sub-elements are described next.

D.2.2.10.1 Subset

Element Specification

ServiceOptions/Subset (0..1)

{At least 1 of the following is required if Subset is used}

1) ServiceOptions/SpatialSubset (0..1)

{At least 1 of the following is required if SpatialSubset is used}

A) ServiceOptions/SpatialSubset/Point (0..1)

ServiceOptions/SpatialSubset/Point/AllowMultipleValues (1) <true, false>

B) ServiceOptions/SpatialSubset/Circle (0..1)

ServiceOptions/SpatialSubset/Circle/AllowMultipleValues (1) <true, false>

C) ServiceOptions/SpatialSubset/Line

ServiceOptions/SpatialSubset/Line/MaximumNumberOfPoints (0..1)

ServiceOptions/SpatialSubset/Line/AllowMultipleValues (1) <true, false>

D) ServiceOptions/SpatialSubset/BoundingBox

ServiceOptions/SpatialSubset/BoundingBox/AllowMultipleValues (1) <true, false>

E) ServiceOptions/SpatialSubset/Polygon

ServiceOptions/SpatialSubset/Polygon/MaximumNumberOfPoints (0..1)

ServiceOptions/SpatialSubset/Polygon/AllowMultipleValues (1) <true, false>

F) ServiceOptions/SpatialSubset/Shapefile

ServiceOptions/SpatialSubset/Shapefile/Format (1) <ESRI, KML, GeoJSON>

ServiceOptions/SpatialSubset/Shapefile/MaximumFileSizeInBytes (0..1)

ServiceOptions/SpatialSubset/Shapefile/MaximumNumberOfPoints (0..1)

2) ServiceOptions/TemporalSubset (0..1)

ServiceOptions/TemporalSubset/AllowMultipleValues (1) <true, false>

3) ServiceOptions/VariableSubset (0..1)

ServiceOptions/VariableSubset/AllowMultipleValues (1) <true, false>

Description

This element is used to identify the list of supported subsetting requests and include the following:

- Subsetting by geographic region
- Subsetting by time
- Subsetting by variable

Sample data:

```

"ServiceOptions": {
  "Subset": {
    "SpatialSubset": {
      "BoundingBox": {
        "AllowMultipleValues": false
      },
      "Polygon": {
        "MaximumNumberOfPoints": 10,
        "AllowMultipleValues": false
      },
      "Shapefile": [{
        "Format": "KML",
        "MaximumFileSizeInBytes": 5000,
        "MaximumNumberOfPoints": 10
      }, {
        "Format": "ESRI",
        "MaximumFileSizeInBytes": 10000,
        "MaximumNumberOfPoints": 20
      }, {
        "Format": "GeoJSON",
        "MaximumFileSizeInBytes": 20000,
        "MaximumNumberOfPoints": 40
      }
    ]
  },
  "TemporalSubset": {
    "AllowMultipleValues": false
  },
  "VariableSubset": {
    "AllowMultipleValues": true
  }
}

```

Tags*Recommended, Controlled Vocabulary*

D.2.2.10.2 VariableAggregationSupportedMethods

Element Specification

ServiceOptions/VariableAggregationSupportedMethods (0..*) <AVG, COUNT, SUM, MIN, MAX, VAR, ANOMOLY>

Description

This element is used to identify the list of supported methods of variable aggregation and include the following:

- ave - Calculate average value(s).

- count - Calculate overall number of data points.
- sum - Calculate sum of all data points.
- min - Calculate minimum value(s).
- max - Calculate maximum value(s).
- var - Calculate variance across value(s).
- anomaly - Calculate anomaly across value(s).

The list above was taken from the MERRA Analytic Services (MAS) example:

<https://cds.nccs.nasa.gov/wp-content/test/MASOverview.html>. MAS enables MapReduce analytics over NASA's Modern-Era Retrospective Analysis for Research and Applications (MERRA) data collection. In this service, a typical average operation can be achieved by sending the following example web service request:

```
http://skyportal.sci.gsfc.nasa.gov/cds/mas/order.php?job_name=avg_T_instM_3d_ana_Np&collection=instM_3d_ana_Np&operation=avg&service_request=GetVariableByCollection_Operation_TimeRange_SpatialExtent_VerticalExtent&variable_list=T&start_date=201101&end_date=201102&min_lon=-125&min_lat=24&max_lon=-66&max_lat=50&start_level=13&end_level=13&overwrite
```

This would result in the following example XML response:

```
<Response>
  <sessionId>37734A627B5E7E74AAB8374586D3D018</sessionId>
  <sessionStatus>Received</sessionStatus>
  <sessionStatusDetail>Map Reduce job submitted at Tue Dec 10 16:29:57 EST
  2013</sessionStatusDetail>
</Response>
```

Tags

Recommended, Controlled Vocabulary

D.2.2.10.3 InterpolationTypes

Element Specification

ServiceOptions/InterpolationTypes (0..*) <Bilinear Interpolation, Bicubic Interpolation, Distance-weighted average resampling, Nearest Neighbor>

Description

This element is used to identify the list of supported interpolation types. This is the method of interpolation used by the service during a regridding operation.

Sample Value: "Bilinear Interpolation, Nearest Neighbor"

Tags

Recommended, Controlled Vocabulary

D.2.2.10.4 SupportedInputProjections and SupportedOutputProjections

Element Specification

ServiceOptions/SupportedInputProjections (0..*)

ServiceOptions/SupportedInputProjections/ProjectionName (0..1) {Valid values are listed in the description section.}

ServiceOptions/SupportedInputProjections/ProjectionLatitudeOfCenter (0..1)

ServiceOptions/SupportedInputProjections/ProjectionLongitudeOfCenter (0..1)

ServiceOptions/SupportedInputProjections/ProjectionFalseEasting (0..1)

ServiceOptions/SupportedInputProjections/ProjectionFalseNorthing (0..1)

ServiceOptions/SupportedInputProjections/ProjectionAuthority (0..1)

ServiceOptions/SupportedInputProjections/ProjectionUnit (0..1)

ServiceOptions/SupportedInputProjections/ProjectionDatumName (0..1)

ServiceOptions/SupportedOutputProjections (0..*)

ServiceOptions/SupportedOutputProjections/ProjectionName (0..1) {Valid values are listed in the description section.}

ServiceOptions/SupportedOutputProjections/ProjectionLatitudeOfCenter (0..1)

ServiceOptions/SupportedOutputProjections/ProjectionLongitudeOfCenter (0..1)

ServiceOptions/SupportedOutputProjections/ProjectionFalseEasting (0..1)

ServiceOptions/SupportedOutputProjections/ProjectionFalseNorthing (0..1)

ServiceOptions/SupportedOutputProjections/ProjectionAuthority (0..1)

ServiceOptions/SupportedOutputProjections/ProjectionUnit (0..1)

ServiceOptions/SupportedOutputProjections/ProjectionDatumName (0..1)

Description

These two elements have the same definition and sub-elements and so they are documented together. These two elements are used to identify the list of supported input and output projection types which have been sourced from the Data Transformation Working Group, have been cited from individual legacy services at the DAACs, or have been requested by the DAACs. The list of valid values includes the following:

- Geographic
- Military Grid Reference
- MODIS Sinusoidal System
- Sinusoidal
- World Mollweide
- Mercator
- Space Oblique Mercator
- Transverse Mercator
- Universal Transverse Mercator
- UTM Northern Hemisphere
- UTM Southern Hemisphere
- State Plane Coordinates
- Albers Equal Area Conic
- Lambert Conic Conformal
- Lambert Equal Area
- Lambert Azimuthal Equal Area

- Cylindrical
- Cylindrical Equal Area
- Polar Stereographic
- EASE-Grid
- EASE-Grid 2.0
- WGS 84 / UPS North (N,E)
- WGS84 - World Geodetic System 1984
- NSIDC EASE-Grid North
- NSIDC EASE Grid Global
- NSIDC Sea Ice Polar Stereographic North
- WGS 84 / NSIDC Sea Ice Polar Stereographic North
- NSIDC EASE Grid North and South (Lambert EA)
- WGS 84 / North Pole LAEA Bering Sea
- WGS 84 / North Pole LAEA Alaska
- WGS 84 / North Pole LAEA Canada
- WGS 84 / North Pole LAEA Atlantic
- WGS 84 / North Pole LAEA Europe
- WGS 84 / North Pole LAEA Russia
- WGS 84 / NSIDC EASE-Grid North
- WGS 84 / NSIDC EASE-Grid Global
- WGS 84 / UTM zone 24N
- Spherical Mercator
- WGS 84 / Pseudo-Mercator -- Spherical Mercator, Google Maps, OpenStreetMap, Bing, ArcGIS, ESRI
- Google Maps Global Mercator -- Spherical Mercator
- WGS 84 / Antarctic Polar Stereographic
- NSIDC EASE-Grid South
- NSIDC Sea Ice Polar Stereographic South
- WGS 84 / NSIDC EASE-Grid South
- WGS 84 / NSIDC Sea Ice Polar Stereographic South
- WGS 84 / UPS South (N,E)
- EASE Grid 2.0 N. Polar
- WELD Albers Equal Area
- Canadian Albers Equal Area Conic
- NAD83 / UTM zone 17N

Depending on the area and the geographic coordinate system used by a projection a datum must be specified. This may be done using the ProjectionDatum element. The projection may also be expressed using the EPSG code. This is sourced from the EPSG Geodetic Parameter Registry: <http://epsg-registry.org>. For example, an EPSG code (Authority) of "4326" corresponds to "WGS84, GeodeticCRS (geographic 2D), over an area of the entire world.

Sample Values:

- ProjectionName: "Geographic"

- ProjectionLatitudeOfCenter: "0"
- ProjectionLongitudeOfCenter: "0"
- ProjectionFalseEasting: "0"
- ProjectionFalseNorthing: "0"
- ProjectionAuthority: "4326"
- ProjectionUnit: "Meters"
- ProjectionDatum: "World Geodetic System (WGS) 1984"

Each sub-element is described next in detail.

Tags

Recommended, Controlled Vocabulary

D.2.2.10.4.1 ProjectionName

Element Specification

ProjectionName (0..1) <"Geographic", "Military Grid Reference", "MODIS Sinusoidal System", "Sinusoidal", "World Mollweide", "Mercator", "Space Oblique Mercator", "Transverse Mercator", "Universal Transverse Mercator", "UTM Northern Hemisphere", "UTM Southern Hemisphere", "State Plane Coordinates", "Albers Equal-Area Conic", "Lambert Conic Conformal", "Lambert Equal Area", "Lambert Azimuthal Equal Area", "Cylindrical", "Cylindrical Equal Area", "Polar Stereographic", "EASE-Grid", "EASE-Grid 2.0", "WGS 84 / UPS North (N,E)", "WGS84 - World Geodetic System 1984", "NSIDC EASE-Grid North", "NSIDC EASE-Grid Global", "NSIDC Sea Ice Polar Stereographic North", "WGS 84 / NSIDC Sea Ice Polar Stereographic North", "NSIDC EASE Grid North and South (Lambert EA)", "WGS 84 / North Pole LAEA Bering Sea", "WGS 84 / North Pole LAEA Alaska", "WGS 84 / North Pole LAEA Canada", "WGS 84 / North Pole LAEA Atlantic", "WGS 84 / North Pole LAEA Europe", "WGS 84 / North Pole LAEA Russia", "WGS 84 / NSIDC EASE-Grid North", "WGS 84 / NSIDC EASE-Grid Global", "WGS 84 / UTM zone 24N", "WGS 84 / Pseudo-Mercator -- Spherical Mercator, Google Maps, OpenStreetMap, Bing, ArcGIS, ESRI", "Google Maps Global Mercator -- Spherical Mercator", "WGS 84 / Antarctic Polar Stereographic", "NSIDC EASE-Grid South", "NSIDC Sea Ice Polar Stereographic South", "WGS 84 / NSIDC EASE-Grid South", "WGS 84 / NSIDC Sea Ice Polar Stereographic South", "WGS 84 / UPS South (N,E)", "NSIDC EASE Grid Global", "EASE Grid 2.0 N. Polar", "Plate Carree", "WELD Albers Equal Area", "Canadian Albers Equal Area Conic", "NAD83 / UTM zone 17N">

Description

This element is used to identify the list of supported input projection types.

Sample Value: "Geographic"

Tags

Recommended, Controlled Vocabulary

D.2.2.10.4.2 ProjectionLatitudeOfCenter

Element Specification

ProjectionLatitudeOfCenter (0..1)

Description

This element is used to identify the origin of the x-coordinates at the center of the projection.

Sample Value: "0"

Tags*Recommended*

D.2.2.10.4.3 ProjectionLongitudeOfCenter

Element Specification

ProjectionLongitudeOfCenter (0..1)

Description

This element is used to identify the origin of the y-coordinates at the center of the projection.

Sample Value: "0"

Tags*Recommended*

D.2.2.10.4.4 ProjectionFalseEasting

Element Specification

ProjectionFalseEasting (0..1)

Description

This element is used to identify the linear value applied to the origin of the y-coordinates. False easting and northing values are usually applied to ensure that all the x and y values are positive.

Sample Value: "0"

Tags*Recommended*

D.2.2.10.4.5 ProjectionFalseNorthing

Element Specification

ProjectionFalseNorthing (0..1)

Description

This element is used to identify the linear value applied to the origin of the x-coordinates. False easting and northing values are usually applied to ensure that all the x and y values are positive.

Sample Value: "0"

Tags

Recommended

D.2.2.10.4.6 ProjectionAuthority

Element Specification

ProjectionAuthority (0..1) <"4326", "3395", "3785", "9807", "2000.63", "2163", "3408", "3410", "6931", "6933", "3411", "9822", "54003", "54004", "54008", "54009", "26917", "900913">

Description

This element is used to identify the authority, expressed as the EPSG code, for the list of supported input projection types.

Sample Value: "4326"

Tags

Recommended, Controlled Vocabulary

D.2.2.10.4.7 ProjectionUnit

Element Specification

ProjectionUnit (0..1) <"Meters", "Degrees">

Description

This element is used to identify the projection unit of measurement.

Sample Value: "Meters"

Tags

Recommended, Controlled Vocabulary

D.2.2.10.4.8 ProjectionDatumName

Element Specification

ProjectionDatumName (0..1) <"North American Datum (NAD) 1927", "North American Datum (NAD) 1983", "World Geodetic System (WGS) 1984">

Description

This element is used to identify the datum names.

Sample Value: "World Geodetic System (WGS) 1984"

Tags*Recommended, Controlled Vocabulary*

D.2.2.10.5 SupportedReformattings

Element Specification

ServiceOptions/SupportedReformattings (0..*)

ServiceOptions/SupportedReformattings/SupportedInputFormats (1)

ServiceOptions/SupportedReformattingsSupportedOutputFormats (1..*)

```
<"HDF4", "HDF5", "HDF-EOS", "HDF-EOS2", "HDF-EOS5", "NETCDF-3", "NETCDF-4",
"GEOTIFF", "GEOTIFFINT16", "GEOTIFFFLOAT32", "XML", "ASCII", "BINARY",
"ICARTT", "PNG", "JPEG", "GIF", "TIFF", "XLSX", "JSON", "CSV", "KML", "PNG24",
"BMP", "ZARR", "Shapefile", "Shapefile+zip", "GeoJSON", "COG", "WKT">
```

Description

This element describes a list of paired input to output formats to which the described service can transform the data. For every input format there is a list of output formats. The following valid formats have been taken from the Data Transformation Working Group:

- hdf4
- hdf5
- hdfeos
- netcdf3
- netcdf4
- geotiff
- xml
- ascii
- icartt
- xlsx
- json
- csv

The rest of the valid formats have been cited from individual legacy services at the DAACs or requested by the DAACs. This list is currently an enumeration within UMM-S; updating the KMS to house and manage Supported Reformating Formats is being considered.

Sample data:

```
[{:SupportedInputFormat "HDF4"
 :SupportedOutputFormats ["GEOTIFFFLOAT32" "HDF4","NETCDF-3","NETCDF-4",
"BINARY","ASCII", "ZARR", "GeoJSON"]}
{:SupportedInputFormat "Shapefile"
 :SupportedOutputFormats ["HDF4","NETCDF-3","NETCDF-4","BINARY","ASCII",
"ZARR", "GeoJSON"]}]])
```

Tags*Recommended, Controlled Vocabulary*

D.2.2.10.6 MaxGranules

Element Specification

ServiceOptions/MaxGranules (0..1)

Description

This field indicates the maximum number of granules which this service can download with one request.

Sample Value: 32767

Tags*Recommended*

D.2.2.11 OperationMetadata

Element Specification

OperationMetadata (0..*)

OperationMetadata/OperationName (0..*)

OperationMetadata/DistributedComputingPlatform (0..*)

OperationMetadata/OperationDescription (0..*)

OperationMetadata/InvocationName (0..*)

OperationMetadata/ConnectPoint (1)

OperationMetadata/OperationChainedMetadata (0..*)

OperationMetadata/CoupledResource (0..*)

OperationMetadata/Parameter (0..*)

Description

This class describes the signature of the operational metadata provided by the service. This element is used to identify the list of operations supported by this service. The term "operation metadata" is a general term to describe the various types of operations which can be involved by a client request in a typical "machine-to-machine" operation to a server. Typical examples of operations available with OGC WMS, WFS, WCS, CSW services include:

- GetCapabilities,
- DescribeCoverage,
- GetCoverage,
- GetMap,
- GetLegendGraphic,
- GetFeatureInfo,
- DescribeFeatureType,
- GetPropertyValue,
- GetFeature,
- GetFeatureWithLock,
- LockFeature,
- Transaction,
- CreateStoredQuery,

- DropStoredQuery,
- ListStoredQueries,
- DescribeStoredQueries

Also, example of operations available with OPeNDAP or Thematic Real-time Environmental Distributed Data Services (THREDDS) services include:

- Spatial Subsetting,
- Temporal Subsetting,
- Variable Subsetting,
- Reformating

Other services offer yet more operations, including Variable Aggregation. These lists are not complete, but representative of typical "machine-to-machine" service operations which are available across NASA.

Tags

Recommended

D.2.2.11.1 OperationName

Element Specification

OperationMetadata/OperationName (0..*) <GetCapabilities, DescribeCoverage, GetCoverage, GetMap, GetLegendGraphic, GetFeatureInfo, DescribeFeatureType, GetPropertyValue, GetFeature, GetFeatureWithLock, LockFeature, Transaction, CreateStoredQuery, DropStoredQuery, ListStoredQueries, DescribeStoredQueries, SPATIAL_SUBSETTING, TEMPORAL_SUBSETTING, VARIABLE_SUBSETTING, VARIABLE_AGGREGATION>

Description

This element contains the name of the operation(s) made possible via this service.

Sample Values:

- Get Capabilities example: "GetCapabilities"
- Describe Coverage example: "DescribeCoverage"
- Get Coverage example: "GetCoverage"

Tags

Recommended, Controlled Vocabulary

D.2.2.11.2 DistributedComputingPlatform

Element Specification

OperationMetadata/DistributedComputingPlatform (0..*) <"XML", "CORBA", "JAVA", "COM", "SQL", "SOAP", "Z3950", "HTTP", "HTTPS", "FTP", "WEBSERVICES">

Description

This element contains the distributed computing platform (protocol) for the operation(s) made possible via this service.

Sample Values:

- Get Capabilities example: "XML, WEBSERVICES "
- Describe Coverage example: "XML, WEBSERVICES "
- Get Coverage example: "XML, WEBSERVICES "

Tags

Recommended, Controlled Vocabulary

D.2.2.11.3 OperationDescription**Element Specification**

OperationMetadata/OperationDescription (0..*)

Description

This element contains the description of the operation(s) made possible via this service.

Sample Values:

- Get Capabilities example: "The GetCapabilities operation provides service metadata including information about contact information, coverage identifiers, capabilities, bounding boxes (extent), authorities (projections) and formats."
- Describe Coverage example: "The DescribeCoverage operation provides service metadata including information about a specific coverage identifier, detailed service capabilities, bounding boxes (extent), authorities (projections), grid axes, labels, time extent and formats."
- Get Coverage example: "The GetCoverage operation response streams the data for a specific coverage identifier, bound by the specified bounding boxes (extent), selected authority (projection), grid axis, time extent and format."

Tags

Recommended

D.2.2.11.4 InvocationName**Element Specification**

OperationMetadata/InvocationName (0..*)

Description

This element contains the name of the invocation of the operation(s) made possible via this service e.g., Spatial Subsetting.

Sample Values:

- GES DISC: "Using the Ozone Monitoring Instrument (OMI) data from NASA Goddard Earth Sciences Data and Information Services Center (GES DISC)"

- ORNL DAAC: "ORNL DAAC WCS Server"

Tags

Recommended

D.2.2.11.5 ConnectPoint

Element Specification

OperationMetadata/ConnectPoint (1)

OperationMetadata/ConnectPoint/ResourceName (0..1)

OperationMetadata/ConnectPoint/ResourceLinkage (1)

OperationMetadata/ConnectPoint/ResourceDescription (0..1)

Description

This element contains the URL of the invocation of the operation(s) made possible via this service.

Sample Values:

- GES DISC WMS: https://disc1.gesdisc.eosdis.nasa.gov/daac-bin/wms_airs?service=WMS&version=1.3.0&request=GetCapabilities
- GES DISC WCS: <https://acdisc.gesdisc.eosdis.nasa.gov/daac-bin/wcsAIRSL3?service=WCS&version=1.0.0&request=GetCapabilities>
- ORNL DAAC WMS:
<https://webmap.ornl.gov/ogcbroker/wms?service=WMS&version=1.3.0&request=GetCapabilities>
- ORNL DAAC WCS:
<https://webmap.ornl.gov/ogcbroker/wcs?service=WCS&version=1.0.0&request=GetCapabilities>

Tags

Recommended

D.2.2.11.5.1 ResourceName

Element Specification

OperationMetadata/ConnectPoint/ResourceName (0..1)

Description

This element contains the name of the resource(s) coupled to this service.

Sample Values:

- GES DISC:
 - "AIRS3STD:TotO3_D" - corresponds to the resource labelled: "Total Column Ozone for Descending Orbit"

- "AIRS3STD:SurfAirTemp_D_timeAveraged" - corresponds to the resource labelled: ";Surface air temperature parameter (in Kelvin) from the AIRS Only level 3 daily gridded product at 1 degree resolution"
- ORNL DAAC:
 - "1000_1" - corresponds to the resource labelled: "Modelled Chlorophyll-a Concentration, June 2002 - December 2003"
 - "1004_27" - corresponds to the resource labelled: "Soil Thermal Capacity with 0 volumetric soil-water fraction at 0-150 cm of Depth"
- NSIDC:
 - "sea_ice_concentration_01" - corresponds to the resource which represents mean ice concentration percentages for each month over the entire time period 1979-2007, which is generated from passive microwave brightness temperature data derived from Nimbus-7 Scanning Multichannel Microwave Radiometer (SMMR) and Defense Meteorological Satellite Program (DMSP) -F8, -F11 and -F13 Special Sensor Microwave/Imager (SSM/I) radiances at a grid cell size of 25 x 25 km.
 - "seasonal_snow_classification" - corresponds to the resource which represents global seasonal snow classification system, which is based on the physical properties of the snow (depth, density, thermal conductivity, number of layers, degree of wetting, etc.), the world's seasonal snow covers are divided into six classes, plus classes for water and ice fields. Each class is defined by its physical properties, then empirically related to climate using three variables (precipitation, wind, and air temperature). A vegetation proxy was used for wind data: tall vegetation equals low wind, short vegetation equals high wind.

Tags

Recommended

D.2.2.10.4.9 ResourceLinkage [R]

Element Specification

OperationMetadata/ConnectPoint/ResourceLinkage (1)

Description

This element contains the URL of the resource(s) coupled to this service.

Sample Values:

- GES DISC:
 - GetCapabilities operation:
 - <https://acdisc.gesdisc.eosdis.nasa.gov/daac-bin/wcsAIRSL3?service=WCS&version=1.0.0&request=GetCapabilities>
 - Response: Server responds by returning the capabilities in an XML file
 - DescribeCoverage operation:
 - https://acdisc.gesdisc.eosdis.nasa.gov/daac-bin/wcsAIRSL3?service=WCS&version=1.0.0&request=DescribeCoverage&coverage=AIRS3STD:SurfAirTemp_D_timeAveraged

- Response: Server responds by returning the capabilities for the specific coverage in an XML file
 - GetCoverage operation:
 - A GeoTIFF of the surface air temperature parameter (in Kelvin) from the AIRS Only level 3 daily gridded product at 1 degree resolution (264 KB): https://acdisc.gesdisc.eosdis.nasa.gov/daac-bin/wcsAIRSL3?service=WCS&version=1.0.0&request=GetCoverage&crs=EPSG:4326&format=geoTiff&resx=1.0&resy=1.0&bbox=-180,-90,180,90&time=2007-06-01&coverage=AIRS3STD:SurfAirTemp_D_timeAveraged
 - Response: Server responds by returning the coverage in a file (AIRS3STD_SurfAirTemp_D_20070601.tif). See figure D-12 to see the file image.

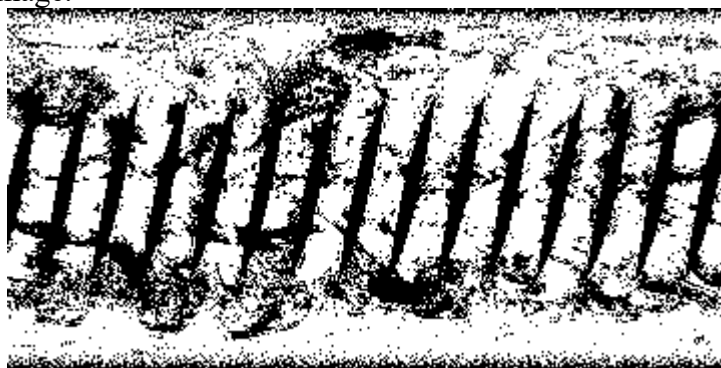

Figure D-12. GeoTIFF file returned in the server response from a GetCoverage request for the AIRS3STD:SurfAirTemp_D_timeAveraged coverage

- ORNL DAAC:
 - GetCapabilities operation:
 - <https://webmap.ornl.gov/ogcbroker/wms?service=WMS&version=1.3.0&request=GetCapabilities>
 - <https://webmap.ornl.gov/ogcbroker/wcs?service=WCS&version=1.0.0&request=GetCapabilities>
 - Response: In each case above the server responds by returning the capabilities in an XML file
 - DescribeCoverage operation:
 - https://webmap.ornl.gov/ogcbroker/wcs?service=WCS&version=1.0.0&coverage=980_14&request=DescribeCoverage
 - Response: Server responds by returning the capabilities for the specific coverage in an XML file
 - GetCoverage operation:
 - A 32 bit GeoTIFF for the Weekly Averages of Sea Surface Temperature (1986) (4.4 MB)]
 - https://webmap.ornl.gov/ogcbroker/wcs?service=WCS&version=1.0.0&request=GetCoverage&crs=EPSG:4326&format=GeoTIFF_FLOAT32&resx=1.0&resy=1.0&bbox=-180,-90,180,90&coverage=980_14

- Response: Server response by returning the coverage in a file (mapserv.tiff). See figure D-13 to see the file image.

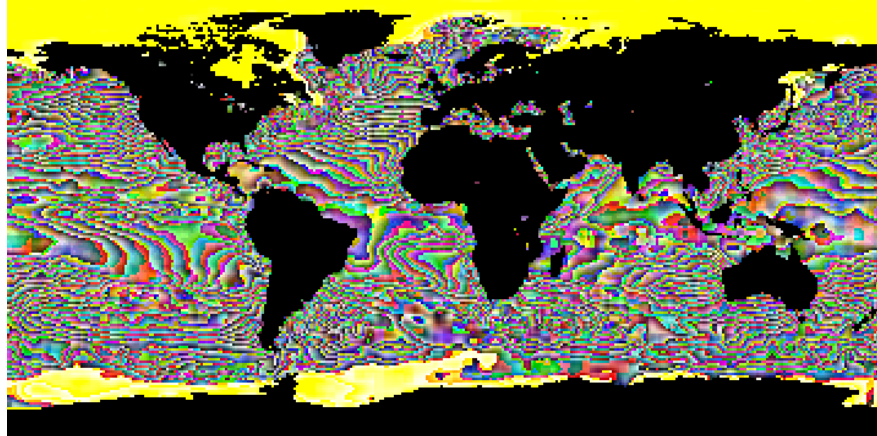

Figure D-13. GeoTIFF file returned in the server response from a GetCoverage request for the 980_14 coverage

- GetMap operation:
 - A PNG image for the LIDAR-derived Vegetation Canopy Structure, Great Smokey Mountains National Park, 2011 (1986) (249 KB)
 - https://webmap.ornl.gov/cgi-bin/mapserv?VERSION=1.1.1&SERVICE=WMS&STYLES=&WIDTH=970&HEIGHT=485&originator=SDAT&LAYERS=1286_1_band1&REQUEST=GetMap&SRS=EPSG:2264&BBOX=503414.334,632612.579,819944.274,790877.549&FORMAT=image/png&TRANSPARENT=true&map=/sdac/config/mapfile//1286/1286_1_wms.map
 - Response: Server response by returning the map in a file (mapserv.png). See figure D-14 to see the file image.

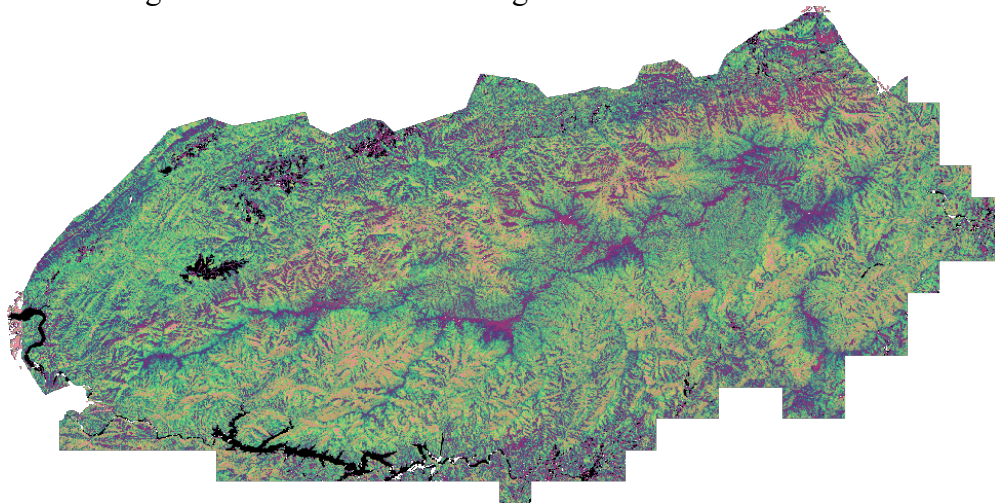

Figure D-14. PNG file returned in the server response from GetMap request for the /sdac/config/mapfile//1286/1286_1_wms.map map

Tags*Recommended*

D.2.2.10.4.10 ResourceDescription

Element Specification

OperationMetadata/ConnectPoint/ResourceDescription (0..1)

Description

This element contains the description of the resource(s) coupled to this service.

Sample Values:

- GES DISC: "Total Column Ozone for Descending Orbit"
- ORNL DAAC: "Modelled Chlorophyll-a Concentration, June 2002 - December 2003"
- NSIDC: "Mean ice concentration percentages for each month over the entire time period 1979-2007, which is generated from passive microwave brightness temperature data derived from Nimbus-7 Scanning Multichannel Microwave Radiometer (SMMR) and Defense Meteorological Satellite Program (DMSP) -F8, -F11 and -F13 Special Sensor Microwave/Imager (SSM/I) radiances at a grid cell size of 25 x 25 km"

Tags*Recommended*

D.2.2.10.6 OperationChainMetadata

Element Specification

OperationMetadata/OperationName (0..*)

OperationMetadata/OperationChainMetadata/OperationChainName (1) <Spatial Subsetting, Temporal Subsetting, Variable Subsetting, Reprojection, Regridding, Format Conversion, Variable Aggregation>

OperationMetadata/OperationChainMetadata/OperationChainDescription (0..1)

Description

This element and its sub-elements contain the name of the chained operation(s) made possible via this service. The OperationChainName element contains the name of the operation chain made possible via this service and the list of valid chained operations as described by the OperationChainName is sourced from the Data Transformation Working Group. The OperationChainDescription element contains the description of the operation chain. Examples of chained operations include but is not limited to Subset/Regrid/Format convert and Subsetting by variable/time/region. To express the operation chain names of Subset/Regrid/Format convert, use the following keywords separated by the "|" delimiter as shown in the samples values below.

Sample Values:

- GES DISC:
 - OperationChainName Value:
 - Spatial Subsetting|Regridding|Format Conversion

- OperationChainDescription Value:
 - Spatial Subsetting, then Reprojecting from Native 1km x 1 km to 10km x 10km grid, then Format conversion from hdf4 to geotiff.

Tags*Recommended, Controlled Vocabulary*

D.2.2.10.7 CoupledResource

Element Specification

OperationMetadata/CoupledResource (0..*)

OperationMetadata/CoupledResource/ScopedName (0..*)

OperationMetadata/CoupledResource/DataResourceDOI (0..*)

OperationMetadata/CoupledResource/DataResource (0..*)

OperationMetadata/CoupledResource/CouplingType (0..*)

Description

This element contains important information about the resource(s) coupled to this service. Each of its sub-elements are described in the following sections.

Tags*Recommended*

D.2.2.11.7.1 ScopedName

Element Specification

OperationMetadata/CoupledResource/ScopedName (0..1)

Description

This element contains the name of the resource(s) coupled to this service.

Sample Value: GES DISC: "WCS Service for AIRS3STD: AIRS/Aqua L3 Daily Standard Physical Retrieval (AIRS-only) 1 degree x 1 degree V006"

Tags*Recommended*

D.2.2.11.7.2 DataResourceDOI

Element Specification

Service/OperationMetadata/CoupledResource/DataResourceDOI (0..*)

Description

This element contains the Digital Object Identifier (DOI) for the resource(s) coupled to this service.

Sample Value: GES DISC: doi:10.5067/Aqua/AIRS/DATA303

Tags*Recommended*

D.2.2.11.7.3 DataResource

Element Specification

OperationMetadata/CoupledResource/DataResource (0..1)

DataResource/DataResourceIdentifier (0..1)

DataResource/DataResourceSourceType (0..1) <Map, Variable, Granule, Collection, Virtual>

DataResource/DataResourceSpatialExtent (0..1)

DataResource/DataResourceSpatialExtent/SpatialPoints (0..*)

DataResource/DataResourceSpatialExtent/SpatialPoints/Latitude (1)

DataResource/DataResourceSpatialExtent/SpatialPoints/Longitude (1)

DataResource/DataResourceSpatialExtent/SpatialLineStrings (0..*)

DataResource/DataResourceSpatialExtent/SpatialLineStrings/StartPoint (1)

DataResource/DataResourceSpatialExtent/SpatialLineStrings/StartPoint/Latitude (1)

DataResource/DataResourceSpatialExtent/SpatialLineStrings/StartPoint/Longitude (1)

DataResource/DataResourceSpatialExtent/SpatialLineStrings/EndPoint (1)

DataResource/DataResourceSpatialExtent/SpatialLineStrings/EndPoint/Latitude (1)

DataResource/DataResourceSpatialExtent/SpatialLineStrings/EndPoint/Longitude (1)

DataResource/DataResourceSpatialExtent/SpatialBoundingBox (0..1)

DataResource/DataResourceSpatialExtent/SpatialBoundingBox/CRSIdentifier (1)

{Enumerations are shown below}

DataResource/DataResourceSpatialExtent/SpatialBoundingBox/WestBoundingCoordinate (1)

DataResource/DataResourceSpatialExtent/SpatialBoundingBox/SouthBoundingCoordinate (1)

DataResource/DataResourceSpatialExtent/SpatialBoundingBox/EastBoundingCoordinate (1)

DataResource/DataResourceSpatialExtent/SpatialBoundingBox/NorthBoundingCoordinate (1)

DataResource/DataResourceSpatialExtent/GeneralGrid (0..1)

DataResource/DataResourceSpatialExtent/GeneralGrid/CRSIdentifier (1) {Enumerations are shown below}

DataResource/DataResourceSpatialExtent/GeneralGrid/Axis (1..*)

DataResource/DataResourceSpatialExtent/GeneralGrid/Axis/AxisLabel (1)

DataResource/DataResourceSpatialExtent/GeneralGrid/Axis/GridResolution (0..1)

DataResource/DataResourceSpatialExtent/GeneralGrid/Axis/Extent (1)

DataResource/DataResourceSpatialExtent/GeneralGrid/Axis/Extent/ExtentLabel (0..1)

DataResource/DataResourceSpatialExtent/GeneralGrid/Axis/Extent/LowerBound (1)

DataResource/DataResourceSpatialExtent/GeneralGrid/Axis/Extent/UpperBound (1)

DataResource/DataResourceSpatialExtent/GeneralGrid/Axis/Extent/UOMLabel (1)

DataResource/DataResourceSpatialExtent/SpatialPolygons (0..*)

DataResource/DataResourceSpatialExtent/SpatialPolygons/Latitude (1)

DataResource/DataResourceSpatialExtent/SpatialPolygons/Longitude (1)

DataResource/DataResourceSpatialType (0..1) <SPATIAL_POINT, SPATIAL_LINE_STRING, BOUNDING_BOX, GENERAL_GRID, SPATIAL_POLYGON>

DataResource/SpatialResolution (0..1)

DataResource/SpatialResolutionUnit (0..1) <Meters, KM, Degrees, Degrees_North, Degrees_East>

DataResource/DataResourceTemporalExtent (0..1)
 DataResource/DataResourceTemporalExtent/DataResourceTimePoints (1..*)
 DataResource/DataResourceTemporalExtent/DataResourceTimePoints/Time (0..1)
 DataResource/DataResourceTemporalExtent/DataResourceTimePoints/Value (0..1)
 DataResource/DataResourceTemporalExtent/DataResourceTimePoints/Description (0..1)
 DataResource/DataResourceTemporalType (0..1) <TIME_STAMP, TIME_SERIES,
 TIME_AVERAGE, TIME_RANGE>
 DataResource/TemporalResolution (0..1)
 DataResource/TemporalResolutionUnit (0..1) <DAY, TWICE_PER_DAY, WEEK, MONTH,
 YEAR>
 DataResource/RelativePath (0..1)

CRSIdentifier <"4326", "3395", "3785", "9807", "2000.63", "2163", "3408", "3410", "6931",
 "6933", "3411", "9822", "54003", "54004", "54008", "54009", "26917", "900913">

Description

This element contains the data identification and scope for the resource(s) coupled to this service. The DataResource class describes the layers, feature types or coverages available from the service. The DataResource/DataResourceSpatialExtent/GeneralGrid class is based on the metadata described in the *OGC Coverage Implementation Schema* document (<http://docs.opengeospatial.org/is/09-146r6/09-146r6.html>). The DataResource/DataResourceSpatialExtent/GeneralGrid/CRSIdentifier element uses the European Petroleum Survey Group (EPSG) numeric code. The EPSG codes are numeric codes associated with coordinate system definitions. For example, EPSG:4326 is geographic WGS84, and EPSG:32611 is UTM zone 11. A full list of ESPGs is available here: <http://www.geotoolkit.org/modules/referencing/supported-codes.html>. All of the sub-elements are described in detail in the following sub-sections in this document.

Tags

Recommended, Controlled Vocabulary

D.2.2.11.7.3.1 DataResourceIdentifier

Element Specification

DataResource/DataResourceIdentifier (0..1)

Description

The identifier of the layer, feature type or coverage available from the service.

Sample Values: "sea_ice_concentration_01" or "seasonal_snow_classification" or "AIRS3STD:TotO3_D" or "AIRS3STD:SurfAirTemp_D_timeAveraged".

Tags

Recommended

D.2.2.11.7.3.2 DataResourceSourceType

Element Specification

DataResource/DataResourceSourceType (0..1) <Map, Variable, Granule, Collection, Virtual>

Description

The resource type of the layer, feature type or coverage available from the service.

Sample Values: "Variable".

Tags*Recommended, Controlled Vocabulary*

D.2.2.11.7.3.3 DataResourceSpatialExtent

Element Specification

DataResource/DataResourceSpatialExtent (0..1)

DataResource/DataResourceSpatialExtent/SpatialPoints (0..*)

DataResource/DataResourceSpatialExtent/SpatialPoints/Latitude (1)

DataResource/DataResourceSpatialExtent/SpatialPoints/Longitude (1)

DataResource/DataResourceSpatialExtent/SpatialLineStrings (0..*)

DataResource/DataResourceSpatialExtent/SpatialLineStrings/StartPoint (1)

DataResource/DataResourceSpatialExtent/SpatialLineStrings/StartPoint/Latitude (1)

DataResource/DataResourceSpatialExtent/SpatialLineStrings/StartPoint/Longitude (1)

DataResource/DataResourceSpatialExtent/SpatialLineStrings/EndPoint (1)

DataResource/DataResourceSpatialExtent/SpatialLineStrings/EndPoint/Latitude (1)

DataResource/DataResourceSpatialExtent/SpatialLineStrings/EndPoint/Longitude (1)

DataResource/DataResourceSpatialExtent/SpatialBoundingBox (0..1)

DataResource/DataResourceSpatialExtent/SpatialBoundingBox/CRSIdentifier (1)

{Enumerations are shown below}

DataResource/DataResourceSpatialExtent/SpatialBoundingBox/WestBoundingCoordinate (1)

DataResource/DataResourceSpatialExtent/SpatialBoundingBox/SouthBoundingCoordinate (1)

DataResource/DataResourceSpatialExtent/SpatialBoundingBox/EastBoundingCoordinate (1)

DataResource/DataResourceSpatialExtent/SpatialBoundingBox/NorthBoundingCoordinate (1)

DataResource/DataResourceSpatialExtent/GeneralGrid (0..1)

DataResource/DataResourceSpatialExtent/GeneralGrid/CRSIdentifier (1) {Enumerations are shown below}

DataResource/DataResourceSpatialExtent/GeneralGrid/Axis (1..*)

DataResource/DataResourceSpatialExtent/GeneralGrid/Axis/AxisLabel (1)

DataResource/DataResourceSpatialExtent/GeneralGrid/Axis/GridResolution (0..1)

DataResource/DataResourceSpatialExtent/GeneralGrid/Axis/Extent (1)

DataResource/DataResourceSpatialExtent/GeneralGrid/Axis/Extent/ExtentLabel (0..1)

DataResource/DataResourceSpatialExtent/GeneralGrid/Axis/Extent/LowerBound (1)

DataResource/DataResourceSpatialExtent/GeneralGrid/Axis/Extent/UpperBound (1)

DataResource/DataResourceSpatialExtent/GeneralGrid/Axis/Extent/UOMLabel (1)

DataResource/DataResourceSpatialExtent/SpatialPolygons (0..*)

DataResource/DataResourceSpatialExtent/SpatialPolygons/Latitude (1)

DataResource/DataResourceSpatialExtent/SpatialPolygons/Longitude (1)**Description**

The spatial extent of the layer, feature type or coverage available from the service. These are coordinate pairs which describe either the point, line string, boundingbox, general grid, or polygon representing the spatial extent. The general grid includes one or more distinct grid axes. Each axis describes what the axis is for (e.g., Latitude or Longitude), its resolution, and its extent bounds including the unit of measure label. Spatial polygons cover an enclosed region described by a series of points. In order to close the polygon, always repeat the first point in the last position in the series.

Sample Values:

- **SpatialPoint example:**
 - DataResource/DataResourceSpatialType: "SPATIAL_POINT"
 - DataResource/DataResourceSpatialExtent/SpatialPoints/Latitude: "34.32"
 - DataResource/DataResourceSpatialExtent/SpatialPoints/Longitude: "-167.63"
- **SpatialLineString example:**
 - DataResource/DataResourceSpatialType: "SPATIAL_LINE_STRING"
 - DataResource/DataResourceSpatialExtent/SpatialLineStrings/StartPoint/Latitude: "23.04"
 - DataResource/DataResourceSpatialExtent/SpatialLineStrings/StartPoint/Longitude: "78.32"
 - DataResource/DataResourceSpatialExtent/SpatialLineStrings/EndPoint/Latitude: "26.75"
 - DataResource/DataResourceSpatialExtent/SpatialLineStrings/EndPoint/Longitude: "78.12"
- **SpatialBoundingBox example:**
 - DataResource/DataResourceSpatialType: "BOUNDING_BOX"
 - DataResource/DataResourceSpatialExtent/SpatialBoundingBox/CRSIdentifier: "4326"
 - DataResource/DataResourceSpatialExtent/SpatialBoundingBox/WestBoundingCoordinate: "-180.0"
 - DataResource/DataResourceSpatialExtent/SpatialBoundingBox/SouthBoundingCoordinate: "-90.0"
 - DataResource/DataResourceSpatialExtent/SpatialBoundingBox/EastBoundingCoordinate: "180.0"
 - DataResource/DataResourceSpatialExtent/SpatialBoundingBox/NorthBoundingCoordinate: "90.0"
- **General Grid example:**
 - DataResource/DataResourceSpatialType: "GENERAL_GRID"
 - DataResource/DataResourceSpatialExtent/GeneralGrid/CRSIdentifier: "4326"
 - DataResource/DataResourceSpatialExtent/GeneralGrid/Axis
 - DataResource/DataResourceSpatialExtent/GeneralGrid/Axis/AxisLabel: "Latitude"
 - DataResource/DataResourceSpatialExtent/GeneralGrid/Axis/GridResolution: "0.01"

- DataResource/DataResourceSpatialExtent/GeneralGrid/Axis/Extent
- DataResource/DataResourceSpatialExtent/GeneralGrid/Axis/Extent/ExtentLabel: "i"
- DataResource/DataResourceSpatialExtent/GeneralGrid/Axis/Extent/LowerBound: "0"
- DataResource/DataResourceSpatialExtent/GeneralGrid/Axis/Extent/UpperBound: "17998"
- DataResource/DataResourceSpatialExtent/GeneralGrid/Axis/Extent/UOMLabel: "Degrees"
- DataResource/DataResourceSpatialExtent/GeneralGrid/Axis/AxisLabel: "Longitude"
- DataResource/DataResourceSpatialExtent/GeneralGrid/Axis/GridResolution: "0.01"
- DataResource/DataResourceSpatialExtent/GeneralGrid/Axis/Extent
- DataResource/DataResourceSpatialExtent/GeneralGrid/Axis/Extent/ExtentLabel: "j"
- DataResource/DataResourceSpatialExtent/GeneralGrid/Axis/Extent/LowerBound: "0"
- DataResource/DataResourceSpatialExtent/GeneralGrid/Axis/Extent/UpperBound: "35999"
- DataResource/DataResourceSpatialExtent/GeneralGrid/Axis/Extent/UOMLabel: " Degrees "
- SpatialPolygon example:
 - DataResource/DataResourceSpatialType: "SPATIAL_POLYGON"
 - DataResource/DataResourceSpatialExtent/SpatialPolygons/Latitude: "36.92"
 - DataResource/DataResourceSpatialExtent/SpatialPolygons/Longitude: "-120.72"
 - DataResource/DataResourceSpatialExtent/SpatialPolygons/Latitude: "37.74"
 - DataResource/DataResourceSpatialExtent/SpatialPolygons/Longitude: "-121.84"
 - DataResource/DataResourceSpatialExtent/SpatialPolygons/Latitude: "41.84"
 - DataResource/DataResourceSpatialExtent/SpatialPolygons/Longitude: "-123.84"
 - DataResource/DataResourceSpatialExtent/SpatialPolygons/Latitude: "35.83"
 - DataResource/DataResourceSpatialExtent/SpatialPolygons/Longitude: "-120.92"
 - DataResource/DataResourceSpatialExtent/SpatialPolygons/Latitude: "36.92"
 - DataResource/DataResourceSpatialExtent/SpatialPolygons/Longitude: "-120.72"

Tags*Recommended, Controlled Vocabulary*

D.2.2.11.7.3.4 DataResourceSpatialType

Element Specification

DataResource/DataResourceSpatialType (0..1) <"SPATIAL_POINT",
"SPATIAL_LINE_STRING", "BOUNDING_BOX", "GENERAL_GRID",
"SPATIAL_POLYGON">

Description

The type of the spatial extent of the layer, feature type or coverage available from the service.

Sample Values: "SPATIAL_POINT".

Tags

Recommended, Controlled Vocabulary

D.2.2.11.7.3.5 SpatialResolution

Element Specification

DataResource/SpatialResolution (0..1)

Description

The spatial resolution of the layer, feature type or coverage available from the service.

Sample Values: "10".

Tags

Recommended

D.2.2.11.7.3.6 SpatialResolutionUnit

Element Specification

DataResource/SpatialResolutionUnit (0..1) <Meters, KM, Degrees_North, Degrees_East>

Description

The unit of the spatial resolution of the layer, feature type or coverage available from the service. For now the enumeration values are managed in the schema implementation, but in the future the enumeration type will be managed by the KMS.

Sample Value: "KM".

Tags

Recommended, Controlled Vocabulary

D.2.2.11.7.3.7 DataResourceTemporalExtent

Element Specification

DataResource/DataResourceTemporalExtent (0..1)

DataResource/DataResourceTemporalExtent/DataResourceTimePoints (1..*)

DataResource/DataResourceTemporalExtent/DataResourceTimePoints/TimeFormat (0..1)

DataResource/DataResourceTemporalExtent/DataResourceTimePoints/TimeValue (0..1)

DataResource/DataResourceTemporalExtent/DataResourceTimePoints/Description (0..1)

Description

The temporal extent of the layer, feature type or coverage available from the service.

Sample Values:

- Time Stamp:
 - DataResource/DataResourceTemporalType: "TIME_STAMP"
 - DataResource/DataResourceTemporalExtent/TimePoints/TimeFormat: "%H:%M:%S"
 - DataResource/DataResourceTemporalExtent/TimePoints/TimeValue "12:20:01"
 - DataResource/DataResourceTemporalExtent/TimePoints/Description "Time stamp of the layer"
- Time Range
 - DataResource/DataResourceTemporalType: "TIME_RANGE"
 - DataResource/DataResourceTemporalExtent/TimePoints/TimeFormat: "%H:%M:%S"
 - DataResource/DataResourceTemporalExtent/TimePoints/TimeValue "12:20:01"
 - DataResource/DataResourceTemporalExtent/TimePoints/Description "First time stamp of the layer"
 - DataResource/DataResourceTemporalExtent/TimePoints/TimeFormat: "%H:%M:%S"
 - DataResource/DataResourceTemporalExtent/TimePoints/TimeValue "current"
 - DataResource/DataResourceTemporalExtent/TimePoints/Description "ongoing"

Tags*Recommended*

D.2.2.11.7.3.8 DataResourceTemporalType

Element Specification

DataResource/DataResourceTemporalType (0..1) <"TIME_STAMP", "TIME_SERIES", "TIME_AVERAGE", "TIME_RANGE">

Description

The type of the temporal extent of the layer, feature type or coverage available from the service.

Sample Values: "TIME_STAMP".

Tags*Recommended, Controlled Vocabulary*

D.2.2.11.7.3.9 TemporalResolution

Element Specification

DataResource/TemporalResolution (0..1)

Description

The temporal resolution of the layer, feature type or coverage available from the service.

Sample Values: "1".

Tags

Recommended

D.2.2.11.7.3.10 TemporalResolutionUnit

Element Specification

DataResource/TemporalResolutionUnit (0..1) <DAY, TWICE_PER_DAY, WEEK, MONTH, YEAR>

Description

The unit of the temporal resolution of the layer, feature type or coverage available from the service. The list is currently managed in the schema implementation, but in the future will be managed by the KMS.

Sample Values: "DAY".

Tags

Recommended, Controlled Vocabulary

D.2.2.11.7.3.11 RelativePath

Element Specification

DataResource/RelativePath (0..1)

Description

Path relative to the root URL for the layer, feature type or coverage service. Some layers are specified as a path relative to the root service endpoint. This element serves to capture this information. The client would simply join the two strings contained in the OperationMetadata/ConnectPoint/ResourceLinkage and DataResource/RelativePath fields to get the fully qualified path to the layer; For example:
https://mydaac.nasa.gov/wms_airsL3/2002/01".

Sample Values: "2002/01"

Tags

Recommended

D.2.2.10.4.11 CouplingType

Element Specification

Service/OperationMetadata/CoupledResource/Resource/CouplingType (0..1) <LOOSE, MIXED, TIGHT>

Description

This element contains the coupling type for the resource(s) coupled to this service.

Sample Values:

- "LOOSE": This is where a variety of data sources (which are not specified precisely) are used to generate the resource.
- "MIXED": This is where a combination of well-cited data sources are used to generate the resource.
- "TIGHT": This is where a single well-cited data source is used to generate the resource.

Tags

Recommended, Controlled Vocabulary

D.2.2.10.8 Parameter

Element Specification

OperationMetadata/Parameter (0..*)

OperationMetadata/Parameter/ParameterName (1)

OperationMetadata/Parameter/ParameterDirection (1)

OperationMetadata/Parameter/ParameterDescription (1)

OperationMetadata/Parameter/ParameterOptionality (1)

OperationMetadata/Parameter/ParameterRepeatability (1)

Description

This element contains important information about the parameter associated with the resource(s) coupled to this service. This element is used where there are one or more parameters listed with a service. The parameters listed here may share the same name as variables (for EOSDIS sourced data resources), and stored elsewhere in UMM. However, many service providers choose alternate names for their parameters, so this class accommodates both these use cases. There is also a use case where a non-EOSDIS source has been chosen as the resource coupled to this service, so an alternate means to name that data resource is provided with this class. The sub-elements are described in detail in the following sub-sections of this document.

D.2.2.11.8.1 ParameterName [R]

Element Specification

OperationMetadata/Parameter/ParameterName (1)

Description

This element contains the name of the parameter associated with the resource(s) coupled to this service. If there is a variable-service association, this field identifies the parameter (variable) name sourced for the service. In the case where there is a non-EOSDIS parameter used as the source for this resource, this field enables the name to be captured in the service operation metadata.

Sample Values:

- "O3_ppbv" - EOSDIS parameter sourced resource.
- "snow_ice_concentration_01" - non-EOSDIS parameter sourced resource.

Tags

Required

D.2.2.11.8.2 ParameterDirection [R]

Element Specification

OperationMetadata/Parameter/ParameterDirection (1) <"IN", "OUT", "IN/OUT">

Description

This element contains the direction of the parameter associated with the resource(s) coupled to this service.

Sample Value: "OUT"

Tags*Required, Controlled Vocabulary*

D.2.2.11.8.3 ParameterDescription [R]

Element Specification

OperationMetadata/Parameter/ParameterDescription (1)

Description

This element contains the description of the parameter associated with the resource(s) coupled to this service.

Sample Value: "ozone mixing ratio reported in parts per billion by volume"

Tags*Required*

D.2.2.11.8.4 ParameterOptionality [R]

Element Specification

OperationMetadata/Parameter/ParameterOptionality (1) <"TRUE", "FALSE">

Description

This element contains the optionality of the parameter associated with the resource(s) coupled to this service.

Sample Value: "TRUE"

Tags*Required, Controlled Vocabulary*

D.2.2.11.8.5 ParameterRepeatability [R]

Element Specification

OperationMetadata/Parameter/ParameterRepeatability (1) <"TRUE", "FALSE">

Description

This element contains the repeatability of the parameter associated with the resource(s) coupled to this service.

Sample Value: "TRUE"

Tags

Required, Controlled Vocabulary

D.2.2.12 ServiceOrganizations [R]

Element Specification

ServiceOrganizations (1..*)

ServiceOrganizations/Roles (1..*) <SERVICE PROVIDER, DEVELOPER, PUBLISHER, AUTHOR, ORIGINATOR>

ServiceOrganizations/ShortName (1)

ServiceOrganizations/LongName (0..1)

ServiceOrganizations/OnlineResource (0..1)

ServiceOrganizations/OnlineResource/Linkage (1)

ServiceOrganizations/OnlineResource/Protocol (0..1)

ServiceOrganizations/OnlineResource/ApplicationProfile (0..1)

ServiceOrganizations/OnlineResource/Name (1)

ServiceOrganizations/OnlineResource/Description (1)

ServiceOrganizations/OnlineResource/Function (0..1)

Description

The service provider, or organization, or institution responsible for developing, archiving, and/or distributing the service. Please note that ShortName and LongName values come from KMS which is a controlled list.

Sample Value: "Role: SERVICE PROVIDER, ShortName: SEDAC, LongName: Socioeconomic Data and Applications Center".

Tags

Required, Controlled Vocabulary

D.2.2.13 ContactPersons

Element Specification:

ContactPersons (0..*)

ContactPersons/Roles (1..*) <SERVICE PROVIDER, DEVELOPER, PUBLISHER, AUTHOR, ORIGINATOR>

ContactPersons/FirstName (0..1)

ContactPersons/MiddleName (0..1)

ContactPersons/LastName (1)
 ContactPersons/ContactInformation (0..1)
 ContactPersons/ContactInformation/RelatedURLs (0..*)
 ContactPersons/ContactInformation/RelatedURLs/URL (1)
 ContactPersons/ContactInformation/RelatedURLs/Description (0..1)
 ContactPersons/ContactInformation/RelatedURLs/URLContentType (1) <CollectionURL,
 PublicationURL, VisualizationURL>
 ContactPersons/ContactInformation/RelatedURLs/Type (1) {Valid values shown below}
 ContactPersons/ContactInformation/RelatedURLs/Subtype (0..1) {Valid values shown below}
 ContactPersons/ContactInformation/ServiceHours (0..1)
 ContactPersons/ContactInformation/ContactInstructions (0..1)
 ContactPersons/ContactInformation/ContactMechanisms (0..*)
 ContactPersons/ContactInformation/ContactMechanisms/Type (1) <Direct Line, Email,
 Facebook, Fax, Mobile, Modem, Primary, TDD/TTY Phone, Telephone, Twitter, U.S. toll free,
 Other>
 ContactPersons/ContactInformation/ContactMechanisms/Value (1)
 ContactPersons/ContactInformation/Addresses (0..*)
 ContactPersons/ContactInformation/Addresses/StreetAddresses (0..*)
 ContactPersons/ContactInformation/Addresses/City (0..1)
 ContactPersons/ContactInformation/Addresses/StateProvince (0..1)
 ContactPersons/ContactInformation/Addresses/PostalCode (0..1)
 ContactPersons/ContactInformation/Addresses/Country (0..1)

Description:

This element includes metadata telling a service user whom they may contact to get information about that service, and how they may contact that person.

Tags

Recommended, Controlled Vocabulary

D.2.2.14 ContactGroups

Element Specification:

ContactGroups (0..*)
 ContactGroups/Roles (1..*) <TECHNICAL CONTACT, User Services, Science Software
 Development>
 ContactGroups/GroupName (1)
 ContactGroups/ContactInformation (0..1)
 ContactGroups/ContactInformation/RelatedURLs (0..*)
 ContactGroups/ContactInformation/RelatedURLs/URL (1)
 ContactGroups/ContactInformation/RelatedURLs/Description (0..1)
 ContactGroups/ContactInformation/RelatedURLs/URLContentType (1) <CollectionURL,
 PublicationURL, VisualizationURL>
 ContactGroups/ContactInformation/RelatedURLs/Type (1) {Valid values shown below}
 ContactGroups/ContactInformation/RelatedURLs/Subtype (0..1) {Valid values shown below}
 ContactGroups/ContactInformation/ServiceHours (0..1)
 ContactGroups/ContactInformation/ContactInstructions (0..1)

ContactGroups/ContactInformation/ContactMechanisms (0..*)
 ContactGroups/ContactInformation/ContactMechanisms/Type (1) <Direct Line, Email, Facebook, Fax, Mobile, Modem, Primary, TDD/TTY Phone, Telephone, Twitter, U.S. toll free, Other>
 ContactGroups/ContactInformation/ContactMechanisms/Value (1)
 ContactGroups/ContactInformation/Addresses (0..*)
 ContactGroups/ContactInformation/Addresses/StreetAddresses (0..*)
 ContactGroups/ContactInformation/Addresses/City (0..1)
 ContactGroups/ContactInformation/Addresses/StateProvince (0..1)
 ContactGroups/ContactInformation/Addresses/PostalCode (0..1)
 ContactGroups/ContactInformation/Addresses/Country (0..1)

Description:

This element includes metadata telling a service user which group they may contact to get information about that service, including how they may contact that group.

Tags

Recommended, Controlled Vocabulary

D.2.2.15 ServiceQuality

Element Specification

ServiceQuality (0..1)
 ServiceQuality/QualityFlag (1) <"Available", "Unavailable", "Reviewed", "Not Reviewed", "Other">
 ServiceQuality/Traceability (0..1)
 ServiceQuality/Lineage (0..1)

Description

Information about the quality of the service, or any quality assurance procedures followed in development.

Sample Value:

- QualityFlag: "Reviewed"
- Traceability: "Ticket#1234: Errors have been reported in ServiceMetadata."
- Lineage: "The service has been reviewed for quality and errors have been found".

Tags

Recommended, Controlled Vocabulary

D.2.2.16 AccessConstraints

Element Specification

AccessConstraints (0..1)

Description

Information about any constraints for accessing the service.

Sample Value: "Registration is required to access this service".

Tags

Recommended

D.2.2.17 UseConstraints

Element Specification

UseConstraints (0..1)

UseConstraints/LicenseUrl (0..1)

UseConstraints/LicenseText (0..1)

Description

Information on how the service may or may not be used after access is granted. This includes any special restrictions, legal prerequisites, terms and conditions, and/or limitations on using the item. Providers may request acknowledgement of the item from users and claim no responsibility for quality and completeness. Use Constraints describes how the service may be used once access has been granted, and is distinct from Access Constraints, which refers to any constraints in accessing the service.

Sample Value:

LicenseUrl: "https://www.usgs.gov/information-policies-and-instructions/crediting-usgs"

LicenseText: "Please credit U.S. Geological Survey as the Service Provider".

Tags

Recommended

D.2.2.18 AncillaryKeywords

Element Specification

AncillaryKeywords (0..1)

Description

Words or phrases to further describe the service.

Sample Value: "Hierarchical Data Format, Document Type Definition, Web Map Service".

Tags

Recommended

Appendix A: Deprecated Elements

With the revisions needed for the End-to-End Services, UI/UX driven approach to services, the elements listed below were removed. These deprecated elements apply to the UMM-S model only. Elements which have these names have not been removed from the UMM-C model.

ServiceOptions/SupportedInputFormats
ServiceOptions/SupportedOutputFormats

Appendix B: Tags Glossary

Table D-2. Tags Glossary

Tag Name	Description
Required	This element is required.
Controlled Vocabulary	This element will have a vocabulary that will be used to validate the value. This will most likely be done via a vocabulary management service.
Recommended	This element is recommended.

Appendix C: Definitions of Terms

This section contains definitions for new concepts introduced in the UMM-S model, i.e. operations, chaining, coupling, resources, etc.

CONCEPT:

Operation

DEFINITION:

A server-side operation which is provided by the service. e.g. GetCoverage.

For example, the OGC - Web Mapping Service (WMS) standard, the list of operations provided by the service is:

WMS specifies a number of different request types, two of which are required by any WMS server:[11]

GetCapabilities – returns parameters about the WMS (such as map image format and WMS version compatibility) and the available layers (map bounding box, coordinate reference systems, URI of the data and whether the layer is mostly opaque or not)

GetMap – returns a map image. Parameters include: width and height of the map, coordinate reference system, rendering style, image format

Request types that WMS providers may optionally support include:

GetFeatureInfo – if a layer is marked as 'queryable' then you can request data about a coordinate of the map image.

DescribeLayer – returns the feature types of the specified layer or layers, which can be further described using WFS or WCS requests. This request is dependent on the SLD Profile of WMS.[12]

GetLegendGraphic – return an image of the map's legend image, giving a visual guide to map elements.

For example, the OGC - Web Coverage Service (WCS) standard, the list of operations provided by the service is:

WCS specified a number of different request types

GetCapabilities – returns parameters about the WCS

DescribeCoverage – returns the coverage types of the specified coverage or coverages,

GetCoverage – returns a coverage in the chosen format. Parameters include: width and height of the coverage, coordinate reference system, resolution, coverage format

For example, for the OGC - Catalog Services for the Web (CSW) standard, the list of operations provided by the service is:

GetCapabilities: "allows CSW clients to retrieve service metadata from a server"

DescribeRecord: "allows a client to discover elements of the information model supported by the target catalogue service. The operation allows some or all of the information model to be described".

GetRecords: search for records, returning record IDs

GetRecordById: "retrieves the default representation of catalogue records using their identifier"

GetDomain (optional): "used to obtain runtime information about the range of values of a metadata record element or request parameter"

Harvest (optional): create/update metadata by asking the server to 'pull' metadata from somewhere

Transaction (optional): create/edit metadata by 'pushing' the metadata to the server

The operation may be combined with other operations. An operation may be called up via a client-side request. The operation is usually involved with some type of metadata or data-fetch from the server. An example of a client-side request is one which requests data via an identifier (of either a map layer or a coverage), then transforms the data in some way from its native form to a desired form, i.e. spatial subsetting, or reformatting.

CONCEPT:

Chaining

DEFINITION:

Chaining is used where two or more server-side operations are cascaded. For example, a client may request the metadata via a GetCapabilities request, followed by a GetCoverage request for a specific data set. In WMS these data layers are identified as maps, conversely in WCS, data layers are identified as coverages, and the service defines a set of identifiers (or names) for each set of maps or coverages.

CONCEPT:

Coupling

DEFINITION:

Coupling is used where data and services are associated. Loosely coupled data is data which is available via a service, but all data may not reside in one place, and may be distributed across various archives, or combined in some fashion at the source. The data may be heterogeneous in format or exist in various sources. Tightly coupled data is data which is available via a service, and the data may be organized in one place and is homogeneous in format or may originate from one source.

CONCEPT:

Request

DEFINITION:

A request is made wherever a client needs to gain data of information from the service. For WMS, the client may request a map. For WCS the client may request a coverage. For CSW, the client may request a catalog service entry, using a search term or terms. For OPeNDAP, the client may request a granule or subset of a granule from a collection.

CONCEPT:

Response

DEFINITION:

Responses are returned to the client in XML or streaming responses from the service. A WMS server usually serves the map in a bitmap format, e.g. PNG, GIF or JPEG and etc... In addition, vector graphics can be included, such as points, lines, curves and text, expressed in SVG or WebCGM format. For WCS, the response is in the form of coverages representing space/time-varying phenomena that relate a spatio-temporal domain to a (possibly multidimensional) range of properties. For CSW the response is in XML format. For OPeNDAP, the response is a download to the browser, or client (web-based or scripted) usually in the output format specified in the client request.

Appendix D: Examples

This section contains some service metadata worked examples.

The following distinct types are represented: Back-end Services (OPeNDAP examples provided).

The first of these service record examples is the AIRS L3 OPeNDAP service.

```
{
  "Name": "AIRS L3 OPeNDAP",
  "LongName": "OPeNDAP (Hyrax) framework for AIRS Level 3 data products",
  "Type": "OPeNDAP",
  "Version": "1.13.4",
  "Description": "OPeNDAP (Hyrax) Framework for AIRS L3 data products. This framework
  facilitates such services as format conversion and selected subsetting (e.g., spatial constraints,
  parameter/variable). ",
  "URL": {
    "Description": "Access to OPeNDAP protocol for AIRS L3 data sets",
    "URLValue": "https://acdisc.gesdisc.eosdis.nasa.gov/opendap/Aqua_AIRS_Level3/contents.html"
  },
  "ServiceKeywords":
  [
    {
      "ServiceCategory": "EARTH SCIENCE SERVICES",
      "ServiceTopic": "DATA MANAGEMENT/DATA HANDLING",
      "ServiceTerm": "DATA DELIVERY"
    },
    {
      "ServiceCategory": "EARTH SCIENCE SERVICES",
      "ServiceTopic": "INFORMATION MANAGEMENT SERVICES",
      "ServiceTerm": "DATA MANAGEMENT/DATA HANDLING",
      "ServiceSpecificTerm": "DATA INTEROPERABILITY"
    },
    {
      "ServiceCategory": "EARTH SCIENCE SERVICES",
      "ServiceTopic": "METADATA HANDLING",
      "ServiceTerm": "METADATA TRANSFORMATION/CONVERSION"
    }
  ],
  "ServiceOptions":
  {
    "Subset": {
      "SpatialSubset": {
        "BoundingBox": {
          "AllowMultipleValues": false
        }
      }
    }
  }
}
```

```

    }
  },
  "VariableSubset": {
    "AllowMultipleValues": true
  }
}
"SupportedInputProjections":
[
  {
    "ProjectionName": "Geographic",
    "ProjectionAuthority": "4326"
  }
],
"SupportedOutputProjections":
[
  {
    "ProjectionName": "Geographic",
    "ProjectionAuthority": "4326"
  }
],
"SupportedReformattings": [{
  "SupportedInputFormat": "HDF4",
  "SupportedOutputFormats": ["HDF4", "NETCDF-3", "NETCDF-4", "BINARY", "ASCII"]
}]
},
"ServiceQuality":
{
  "QualityFlag": "Available"
},
"ServiceOrganizations" : [
{
  "Roles": ["SERVICE PROVIDER"],
  "ShortName": "NASA/GSFC/SED/ESD/GCDC/GESDISC",
  "LongName": "Goddard Earth Sciences Data and Information Services Center (formerly
Goddard DAAC), Global Change Data Center, Earth Sciences Division, Science and Exploration
Directorate, Goddard Space Flight Center, NASA",
  "OnlineResource": {
    "Name": "GESDISC",
    "Description": "Goddard Earth Sciences Data and Information Services Center",
    "Linkage": "https://disc.gsfc.nasa.gov/"
  }
}
],
"ContactGroups": [{
  "Roles" : [ "SERVICE PROVIDER"],
  "ContactInformation" : {

```



```

    "ContactMechanisms" : [ {
      "Type" : "Email",
      "Value" : "gsfc-help-disc@lists.nasa.gov"
    }, {
      "Type" : "Fax",
      "Value" : "605-594-6589"
    }, {
      "Type" : "Telephone",
      "Value" : "605-594-6151"
    } ],
    "Addresses" : [ {
      "StreetAddresses" : ["Goddard Space Flight Center", "Code 610.2"],
      "City" : "Greenbelt",
      "StateProvince" : "MD",
      "Country" : "USA",
      "PostalCode" : "20771"
    } ]
  },
  "GroupName" : "Service Provider Personnel First Name"
}],
"ContactPersons": [{
  "Roles" : [ "SERVICE PROVIDER"],
  "ContactInformation" : {
    "ContactMechanisms" : [ {
      "Type" : "Email",
      "Value" : "gsfc-help-disc@lists.nasa.gov"
    }, {
      "Type" : "Fax",
      "Value" : "605-594-6589"
    }, {
      "Type" : "Telephone",
      "Value" : "605-594-6151"
    } ],
    "Addresses" : [ {
      "StreetAddresses" : ["Goddard Space Flight Center", "Code 610.2"],
      "City" : "Greenbelt",
      "StateProvince" : "MD",
      "Country" : "USA",
      "PostalCode" : "20771"
    } ]
  },
  "FirstName" : "Service Provider Personnel First Name",
  "MiddleName" : "Service Provider Personnel Middle Name",
  "LastName" : "Service Provider Personnel Last Name"
}]
}

```

The second of these service record examples is the GLDAS OPeNDAP service.

```
{
  "Name": "GLDAS OPeNDAP",
  "LongName": "OPeNDAP Hyrax (1.13.4)",
  "Type": "OPeNDAP", "Version": "1.13.4",
  "Description": "OPeNDAP Hyrax offers all GLDAS datasets, and facilitates variable and
spatial subsetting and format conversion.",
  "URL": {
    "Description": "Access to OPENDAP protocol for GLDAS data sets",

"URLValue": "https://acdisc.gesdisc.eosdis.nasa.gov/opensdap/Aqua_AIRS_Level3/contents.html
"
  },
  "ServiceOptions": {
    "Subset": {
      "SpatialSubset": {
        "BoundingBox": {
          "AllowMultipleValues": false
        }
      },
      "TemporalSubset": {
        "AllowMultipleValues": false
      },
      "VariableSubset": {
        "AllowMultipleValues": true
      }
    }
  },
  "SupportedReformattings": [
    {
      "SupportedInputFormat": "ASCII",
      "SupportedOutputFormats": ["ASCII", "NETCDF-3", "NETCDF-4"]
    },
    {
      "SupportedInputFormat": "NETCDF-3",
      "SupportedOutputFormats": ["ASCII", "NETCDF-3", "NETCDF-4"]
    },
    {
      "SupportedInputFormat": "NETCDF-4",
      "SupportedOutputFormats": ["ASCII", "NETCDF-3", "NETCDF-4"]
    }
  ],
  "ServiceKeywords":
  [
    {
      "ServiceCategory": "EARTH SCIENCE SERVICES",
      "ServiceTopic": "DATA MANAGEMENT/DATA HANDLING",
      "ServiceTerm": "DATA INTEROPERABILITY"
    }
  ],
}
```

```

{
  "ServiceCategory":"EARTH SCIENCE SERVICES",
  "ServiceTopic":"DATA MANAGEMENT/DATA HANDLING",
  "ServiceTerm":"DATA DELIVERY"
},
{
  "ServiceCategory":"EARTH SCIENCE SERVICES",
  "ServiceTopic":"DATA MANAGEMENT/DATA HANDLING",
  "ServiceTerm":"SUBSETTING/SUPERSETTING"
},
{
  "ServiceCategory":"EARTH SCIENCE SERVICES",
  "ServiceTopic":"DATA MANAGEMENT/DATA HANDLING",
  "ServiceTerm":"TRANSFORMATION/CONVERSION"
}],
"ServiceOrganizations" : [
{
  "Roles": ["SERVICE PROVIDER"],
  "ShortName": "NASA/GSFC/SED/ESD/GCDC/GESDISC",
  "LongName": "Goddard Earth Sciences Data and Information Services Center (formerly
Goddard DAAC), Global Change Data Center, Earth Sciences Division, Science and Exploration
Directorate, Goddard Space Flight Center, NASA",
  "OnlineResource": {
    "Name": "GESDISC",
    "Description": "Goddard Earth Sciences Data and Information Services Center",
    "Linkage": "https://disc.gsfc.nasa.gov/"
  }
}
],
"ContactGroups": [{
  "Roles" : [ "SERVICE PROVIDER"],
  "ContactInformation" : {
    "ContactMechanisms" : [ {
      "Type" : "Email",
      "Value" : "gsfc-help-disc@lists.nasa.gov"
    }, {
      "Type" : "Fax",
      "Value" : "605-594-6589"
    }, {
      "Type" : "Telephone",
      "Value" : "605-594-6151"
    }
  ],
  "Addresses" : [ {
    "StreetAddresses" : ["Goddard Space Flight Center","Code 610.2"],
    "City" : "Greenbelt",
    "StateProvince" : "MD",

```

```
        "Country" : "USA",
        "PostalCode" : "20771"
    } ]
  },
  "GroupName" : "Service Provider Group Name"
}],
"ContactPersons": [{
  "Roles" : [ "SERVICE PROVIDER"],
  "ContactInformation" : {
    "ContactMechanisms" : [ {
      "Type" : "Email",
      "Value" : "gsfc-help-disc@lists.nasa.gov"
    }, {
      "Type" : "Fax",
      "Value" : "605-594-6589"
    }, {
      "Type" : "Telephone",
      "Value" : "605-594-6151"
    }
  ] },
  "Addresses" : [ {
    "StreetAddresses" : ["Goddard Space Flight Center", "Code 610.2"],
    "City" : "Greenbelt",
    "StateProvince" : "MD",
    "Country" : "USA",
    "PostalCode" : "20771"
  } ]
},
"FirstName" : "Service Provider Personnel First Name",
"MiddleName" : "Service Provider Personnel Middle Name",
"LastName" : "Service Provider Personnel Last Name"
}]
}
```

Appendix E: Abbreviations and Acronyms

API	Application Programming Interface
CMR	Common Metadata Repository
CSW	Catalog Service for the Web
CSV	Comma-Separated Values
DAAC	Distributed Active Archive Center
DMSP	Defense Meteorological Satellite Program
DODS	Distributed Oceanographic Data System
DOI	Digital Object Identifier
ECHO	Earth Observing System (EOS) Clearing House
EDSC	Earthdata Search
EOS	Earth Observing System
EOSDIS	Earth Observing System Data and Information System
EPSG	European Petroleum Survey Group
ESDIS	Earth Science Data and Information System
ESI	EOSDIS Service Interface
ESO	ESDIS Standards Office
GCMD	Global Change Master Directory
GES DISC	Goddard Earth Sciences Data and Information Services Center
ISO	International Organization for Standardization
KB	Kilobyte
KMS	Keyword Management System
KVP	Key-Value Pair
MAS	Metadata Architecture Studies
MB	Megabyte
MERRA	Modern-Era Retrospective Analysis for Research and Applications
MMT	Metadata Management Tool
NAD	North American Datum
NASA	National Aeronautics and Space Administration
NOAA	National Oceanic and Atmospheric Administration
NSIDC	National Snow and Ice Data Center
OGC	Open Geospatial Consortium
OMI	Ozone Monitoring Instrument
OPeNDAP	Open-source Project for a Network Data Access Protocol
ORNL	Oak Ridge National Laboratory
REST	Representational State Transfer
SEDAC	Socioeconomic Data and Applications Data Center
SERF	Service Entry Resource Format

SMMR	Scanning Multichannel Microwave Radiometer
SMM/I	Special Sensor Microwave/Imager
THREDDS	Thematic Real time Environment Distributed Data Services
UI	User Interface
UML	Unified Modeling Language
UMM	Unified Metadata Model
UMM-C	Unified Metadata Model - Collections
UMM-G	Unified Metadata Model - Granules
UMM-S	Unified Metadata Model - Services
UMM-Var	Unified Metadata Model - Variables
URL	Uniform Resource Locator
USGS	United States Geological Survey
UI/UX	User Interface/User Experience
WCS	Web Coverage Service
WFS	Web Feature Service
WMS	Web Mapping Service
WPS	Web Processing Service
XML	Extensible Markup Language
XPath	XML Path Language
XSLT	Extensible Stylesheet Language Transformations